

Petrol Chain Saw (45.8 cm³)

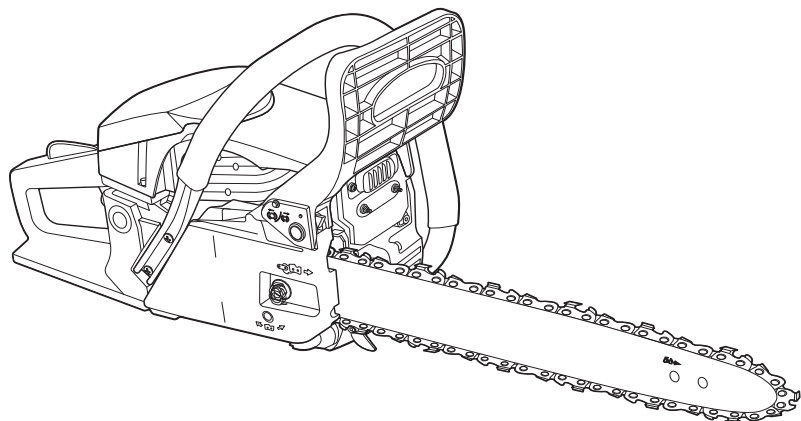

Original Instructions – FPCSP46-2__V10820

FPCSP46-2

EAN: 5059340141343

BX220IM



WARNING: Read the instructions before using the product!

Let's get started...

These instructions are for your safety. Please read through them thoroughly before use and retain them for future reference.



Getting **Started...** 02

| | |
|---------------------------|----|
| Safety information | 03 |
| Your product | 13 |
| Before you start | 16 |
| Quick start | 27 |



In more detail... 29

| | |
|-------------------------------------|----|
| Product functions | 29 |
| Operation | 32 |
| Care and maintenance | 42 |
| Troubleshooting | 52 |
| Recycling and disposal | 54 |
| Guarantee | 54 |
| EC declaration of conformity | 55 |

Safety warnings

1. This product is not intended for use by children and persons with reduced physical, sensory or mental capabilities, or lack of experience and knowledge.
2. Children should be supervised to ensure that they do not play with the product.



WARNING! Your safety and the safety of others is very important. Of course, it is not practical or possible to warn you about all the hazards associated with operating or maintaining this product. At all times you must use your own good judgment.

Petrol powered chain saw safety warnings

1. This product is dangerous if used carelessly or incorrectly and can cause serious or even fatal injuries.
2. Read all instructions carefully. When using petrol powered products, always follow stated safety precautions to reduce the risk of serious personal injury and/or damage to the product.
3. The product should only be operated by those who have read and understood all safety and operating instructions in this manual. Local regulations can restrict the age of the operator.
4. Keep the work area free from pets, animals, children and bystanders.
5. Follow instructions for lubricating, chain tensioning and changing accessories. Improperly tensioned or lubricated chain may either break or increase the chance for kickback. It may cause the chain to snap, which could lead to serious or even fatal injuries.
6. Running this product in a confined or badly ventilated area can result in death due to asphyxiation or carbon monoxide poisoning. The product is for outdoor use only.
7. Take extreme care in wet and freezing weather conditions. Do not work in rain, windy or stormy weather.
8. Wear a face and breathing mask. The use of this product can generate exhaust gases, lubrication oil mist and saw dust containing chemicals known to cause respiratory damage.
9. Wear safety steel toe capped footwear, sturdy cut retardant snug-fitting protective clothing, protective gloves, eye, hearing and head protection devices.
10. Always visually check the product before use.
11. Do not attempt to tackle any job that you are not adequately trained for.
12. Do not allow other persons to be near when starting or cutting with the product.
13. Keep bystanders and animals at least 15 metres out of the work area.
14. Do not operate the product if it has faulty safety equipment or damaged parts.

15. Do not under any circumstances modify the product. Modifications can result in serious personal injury or death.
16. Do not start cutting until you have a clear work area and secure footing.
17. All product servicing and maintenance, other than the items listed in this manual, should be performed by an authorised service centre.
18. First time user should have practical instruction in the use of the product and protective equipment from an experienced operator.
19. National regulation can restrict the use of the product.

Clothing and personal protective equipment (PPE)

1. Secure long hair so that they are above the shoulder level.
2. Do not wear loose fitting clothing or jewellery as those could be drawn into the engine, catch the chain or undergrowth.
3. Use the following safety clothing and personal protective equipment (PPE) when operating the product:
 - > Helmet with visor and neck guard - (compliant to EN 397)
 - > Hearing protection
 - > Dust mask
 - > Gloves with approved saw protection (compliant to EN 381-4, EN 381-7, EN 420:1, EN 388 Class 0)
 - > Protective leggings with approved saw protection (compliant to EN 381-5, EN 340 Class 1)
 - > Slip-resistant steel toe cap boots with approved saw protection (compliant to EN 345-2 Class 2)
 - > First Aid Kit in case of injury

Fuel handling

1. Fuel vapour pressure may build up inside the fuel tank depending on the fuel used, weather conditions and the tank venting system. To reduce the risk of burns and other personal injuries, remove the fuel tank cap carefully to allow any pressure build up to release slowly.
2. Fuel and fuel vapour are highly flammable. Take care when handling fuel and saw chain oil.
3. Be aware of fire risks, explosion and inhalation risks.
4. Do not smoke while operating the product, handling fuel or near fuel.
5. Ensure the spark plug connector is secure. Loose connector may cause electrical arcing that could ignite combustible fumes and cause a fire or explosion.
6. Always switch off the engine before refilling the fuel or oil tanks.
7. Keep the saw chain oil at a sufficient level. Failure to maintain sufficient oil level might damage the product and shorten its lifespan.
8. Check regularly for leaks from the fuel tank cap, oil tank cap and fuel lines.

9. Use caution when handling fuel. To avoid any accidental fires, move the product at least 3 metres from the fuelling point before starting the engine.
10. Tighten the fuel tank cap thoroughly after refilling the fuel tank.
11. Do not operate the product if it is leaking fuel or chain oil.
12. Do not remove the fuel tank cap while the engine is running.
13. Do not store cans of fuel or refill the fuel tank in any place where there is a boiler, stove, wood fire, electrical sparks, welding sparks, or other sources of heat or fire which might ignite the fuel.
14. If any fuel spillage occurs during refuelling, use a dry rag to wipe up spills and allow remaining fuel to evaporate before starting the engine on again.
15. If you have spilt fuel on yourself or on your clothes, change your clothes and wash any part of your body that has come in contact with fuel before turning the engine on again.
16. If fuel has ignited, put out the fire with a dry powder fire extinguisher.

Getting started

1. Do not operate the product indoors. The product produces poisonous exhaust fumes whilst the engine is running which may be colourless and odourless.
2. Do not wrap the recoil starter rope around your hand whilst starting the product. This may result in injuries to your hand or fingers.
3. Keep handles dry, clean and free from oil and grease. Greasy, oily handles are slippery and may cause loss of control.
4. Do not operate the product with a slack chain. A slack chain may jump off the guide bar and cause serious or even fatal injuries.
5. Do not operate the product with one hand! Serious injury to the operator or bystanders may result from one handed operation.
6. Keep all parts of the body away from the saw chain when the chain saw is operating. Before starting the engine, make sure the saw chain is not contacting anything and is free from obstructions. A moment of inattention while operating the chain saw may cause entanglement of your clothing or body with the saw chain.
7. Stop the engine before placing the product down.
8. Check for signs of wear or damage before each use, after any impact or if the product has been dropped. Repair the product if necessary.

Operation

1. When sawing ensure the product does not touch any foreign materials such as rocks, fences, nails etc. Such objects may be flung out and could result in damage to the product, serious or even fatal injuries.
2. Never operate the product on a ladder or other insecure support.
3. If the chain jams in the cut: STOP THE ENGINE. Do not try to pull the product free. Use a lever to open the cut and free the chain. Failure to do so could result in serious or even fatal injuries.
4. Only cut with the engine at high speed in order to avoid blockage.
5. Use extreme caution when cutting small size bushes and saplings. Slender material may catch the saw chain and whip toward the operator or put the operator off balance.
6. Operate the product only in well ventilated areas.
7. Do not operate the product with one hand! This product is intended for two handed use only. Place right hand on the rear handle and left hand on the front handle. You cannot control reactive forces and you may lose control of the product, which may result in the skating or bouncing of the bar and chain along the limb or log.
8. Do not operate the product if you are tired or ill.
9. Do not operate the product under the influence of drugs, alcohol or medication.
10. Do not operate the product if you have any medical conditions that might be aggravated by strenuous work. Consult a doctor before operating this product.
11. Do not touch the exhaust during use - IT GETS VERY HOT during use.
12. Do not operate the product if it is damaged, improperly adjusted, or not completely and securely assembled. Make sure that the saw chain stops moving when the throttle trigger is released.
13. Do not operate the product on a tree unless you have been specifically trained to do so. Operation of the product while up on a tree may result in serious or even fatal injuries.
14. Do not operate the product near or around flammable liquids or gases.
15. Do not smoke whilst operating the product.
16. Do not lock the product over fixed stands.
17. Do not grip the handles with constant or excessive pressure. This might increase the feeling of vibration and the risk of "Vibration White Finger (VWF)" disease.
18. Do not over-reach when operating the product or cut above shoulder height.
19. When cutting a limb (branch) that is under tension, be alert for spring back so that you will not be struck when the tension in the wood fibres is released.
20. Always keep proper footing and operate the chain saw only when standing on fixed, secure and level surface. Slippery or unstable surfaces such as ladders may cause a loss of balance or control of the chain saw.
21. Cut wood only. Do not use the product for purposes not intended. For example, do not use chain saw for cutting plastic, masonry or non-wood building materials. Use of the chain saw for operations different than intended could result in a hazardous situations.

Transport and storage

1. Stop the engine and engage the chain brake before transporting the product.
2. Carry the product with the engine stopped, the guide bar and saw chain to the rear, and the exhaust away from the body.
3. Fit the guide bar cover on the saw chain during transportation or storage.
4. Only carry the product in a horizontal position. Grip the front handle in a manner that the product is balanced horizontally.
5. Secure the product when transporting in a vehicle to prevent turnover, fuel spillage and damage to the product. Use line or ratchet tie-down if necessary.
6. Store the product and fuel so that there is no risk of leakages or fumes coming into contact with sparks or naked flames from electrical equipment, electric motors, relays/switches, boilers etc.
7. For longer periods of storage or transportation the fuel and chain oil tanks must be emptied. Dispose of waste oil and fuel at a local petrol station, local authority centre or where facilities exist.
8. Store fuel and oil in an approved container specifically designed for that purpose.
9. Clean the product and have it serviced before any long-term storage

Causes and operator prevention of kickback

Kickback may occur when the nose or tip of the guide bar touches an object, or when the wood closes in and pinches the saw chain in the cut.

Tip contact in some cases may cause a sudden reverse reaction, kicking the guide bar up and back towards the operator.

Pinching the saw chain along the top of the guide bar may push the guide bar rapidly back towards the operator.

Either of these reactions may cause you to lose control of the saw which could result in serious personal injury. Do not rely exclusively upon the safety devices built into the chain saw. As a chain saw operator, take several steps to keep the cutting jobs free from accidents or injuries.

Kickback is the result of tool misuse and/or incorrect operating procedures or conditions. It can be avoided by taking proper precautions as given below:

1. **Maintain a firm grip, with thumbs and fingers encircling the chain saw handles, with both hands on the saw and position your body and arm to allow you to resist kickback forces.** Kickback forces can be controlled by the operator, if proper precautions are taken. Do not let go of the chain saw.
2. **Do not overreach and do not cut above shoulder height.** This helps prevent unintended tip contact and enables better control of the chain saw in unexpected situations.

- Getting Started . . .
- 3. Only use replacement bars and chains specified by the manufacturer.** Incorrect replacement bars and chains may cause chain breakage and/or kickback.
 - 4. Follow the manufacturer's sharpening and maintenance instructions for the saw chain.** Decreasing the depth gauge height can lead to increased kickback.

Vibration and noise reduction

To reduce the impact of noise and vibration emission, limit the time of operation, use low-vibration and low-noise operating modes as well as wear personal protective equipment.

Take the following points into account to minimise the vibration and noise exposure risks:

1. Only use the product as intended by its design and these instructions.
2. Ensure that the product is in good condition and well maintained.
3. Use correct attachments for the product and ensure they in good condition.
4. Keep a tight grip on the handles/gripping surfaces.
5. Maintain this product in accordance with these instructions and keep it well lubricated (where appropriate).
6. Plan your work schedule to spread any high vibration tool use across a longer period of time.

Emergency

Familiarise yourself with the use of this product by means of this instruction manual. Memorise the safety directions and follow them to the letter. This will help to prevent risks and hazards.

- 1. Always be alert when using this product, so that you can recognise and handle risks early.** Fast intervention can prevent serious injury and damage to property.
- 2. Stop the engine and set the stop switch to O position if there are malfunctions.** Have the product checked by a qualified professional and repaired, if necessary, before you operate it again.
- 3. In case of fire stop the engine and set the stop switch to O position.** Take fire-extinguishing measures immediately if the product switch is no longer accessible.



WARNING! Never use water to extinguish the product on fire. Burning fuel must be extinguished with special extinguishing agents! We recommend that you keep a suitable fire extinguisher within reach in your work area! We recommend to have dry powder fire extinguisher always available.

Residual risks

Even if you are operating this product in accordance with all the safety requirements, potential risks of injury and damage remain. The following dangers can arise in connection with the structure and design of this product:

1. Health defects resulting from vibration emission if the product is used over long periods of time or not adequately managed and properly maintained.
2. Injuries and damage to property due to broken application tools or the sudden impact of hidden objects during use.
3. Danger of injury and property damage caused by flying objects.
4. Burns, if touching hot surfaces.





WARNING! This product produces an electromagnetic field during operation! This field may under some circumstances interfere with active or passive medical implants! To reduce the risk of serious or fatal injury, we recommend persons with medical implants to consult their doctor and the medical implant manufacturer before operating this product!

Symbols

On the product, the rating label and within these instructions you will find among others the following symbols and abbreviations. Familiarise yourself with them to reduce hazards like personal injuries and damage to property.

| | | | |
|---------------------------|---|------------------|---------------------------|
| kW | Kilowatt | l | Litre |
| cm ³ | Cubic centimetre | ml | Millilitre |
| /min or min ⁻¹ | Per minute | °C | Degree Celsius |
| mm | Millimetre | dB(A) | Decibel (A-rated) |
| cm | Centimetre | m/s ² | Metres per second squared |
| kg | Kilogram | | |
| mm.yyyy | Manufacturing date code; year of manufacturing (yyyy) and month of manufacturing (mm) | | |

Description of signal words:

-  **DANGER!** The signal word that indicates a hazard with a high level of risk which, if not avoided, will result in death or serious injury.
-  **WARNING!** The signal word that indicates a hazard with a medium level of risk which, if not avoided, could result in death or serious injury.
-  **CAUTION!** The signal word that indicates a hazard with a low level of risk which, if not avoided, could result in minor or moderate injury.
- NOTE!** Indicates a practical tip, advice or practice not related to personal injury.



Caution/Warning.
Read the instruction manual.



Wear dust mask.



Wear helmet with visor and neck guard - (compliant to EN 397)
Wear hearing protection (compliant to EN 352-1)



Do not expose the product to rain or wet conditions.



Open flames in the work area, around the product and in the vicinity of flammable materials are prohibited!



Do not smoke in the work area, around the product and in the vicinity of flammable materials!



Risk of fire/flammable materials.



Hot surface, do not touch! High temperatures on the product's surfaces and structural parts that could cause burns, if they are touched. The product can also stay hot for a longer period of time after the operation!



Note/Remark.



Wear slip-resistant steel toe cap boots with approved saw protection (compliant to EN 345-2 Class 2)



Gloves with approved saw protection (compliant to EN 381-4, EN 381-7, EN 420:1, EN 388 Class 0)



Wear protective leggings with approved saw protection (compliant to EN 381-5, EN 340 Class 1)



Petrol engines produce toxic carbon monoxide exhaust fumes. Breathing carbon monoxide can cause nausea, fainting or even death. Do not operate the engine indoors!



Always hold the product firmly in both hands.



Kickback! Tip contact may cause the guide bar to move suddenly upward and backwards what may cause serious injury to user.



Contact of the guide bar tip with any object should be avoided.



Stop the engine before refuelling. Never refuel the product while the engine is running.

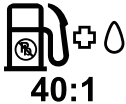

Only refuel unleaded petrol and oil mixture in ratio 40:1. Do not use any other mixture ratio.



Filling for fuel-oil mixture.



Filling for saw chain oil.



Direction of the saw chain.



Indication of chain oil flow adjuster; location: bottom.



Indication of chain tension adjuster; location: side.

H
L
T

High-speed mixture adjuster for adjusting fuel delivery at full throttle.

Low-speed mixture adjuster for adjusting fuel delivery at idling speed.

Idle-speed adjuster for adjusting the idling speed.



Stop the engine and disconnect the spark plug connector before assembly, cleaning, adjustments, maintenance, storage and transportation.



Choke – CLOSE position.



Choke – OPEN position.



Stop switch positions. Stop the engine.



Press the primer 8 times before starting the cold engine.



Objects thrown by the product could hit the operator or other bystanders. Always ensure that other people and pets remain at a safe distance from the product when it is in operation. In general, children must not come near the area where the product is operating.

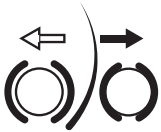

Chain brake (the  symbol shows the position in which the brake is released)



Engine manual start; recoil starter.



Guaranteed sound power level value in dB.

FPCSP46-2

Designation of the tool
(**FP**_Brand Name; **CS**_Chain Saw; **P**_Petrol power)



The product complies with the applicable European directives and an evaluation method of conformity for these directives was done.

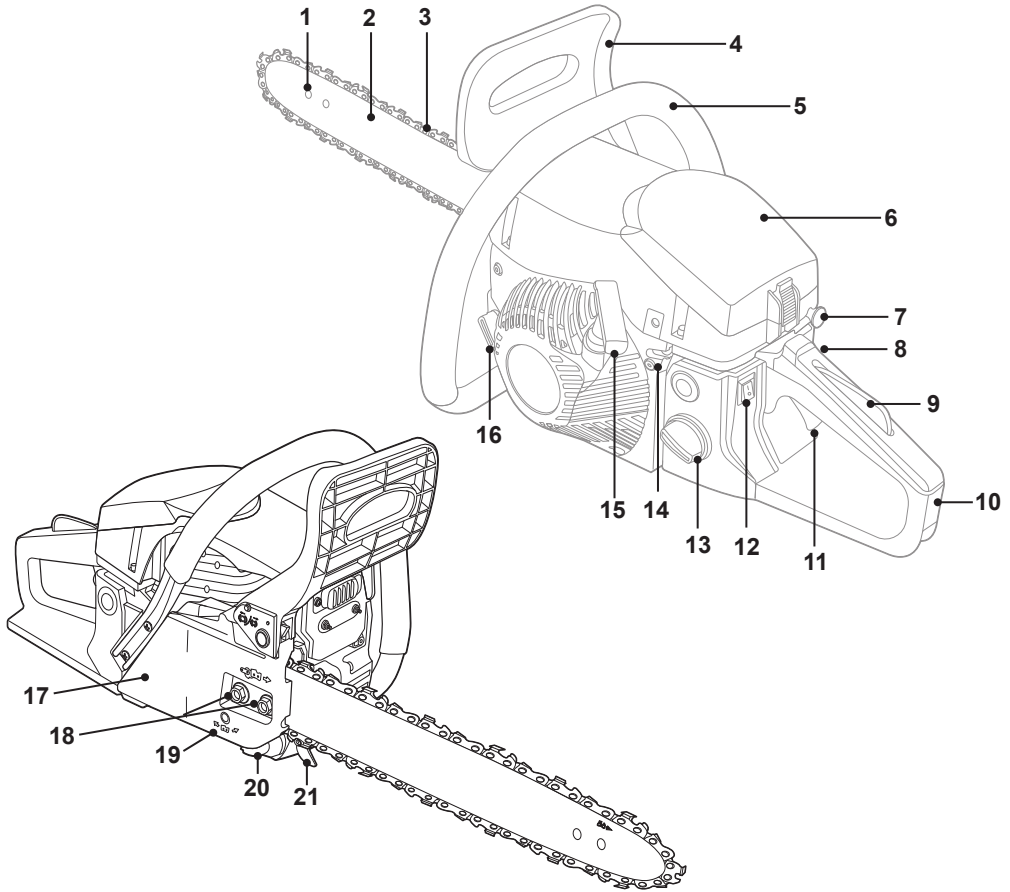

- | | |
|--|-------------------------------------|
| 1. Lubrication holes (on both sides) | 12. Stop switch |
| 2. Guide bar | 13. Fuel tank cap |
| 3. Saw chain | 14. Adjusting screws for carburetor |
| 4. Front hand guard (with chain brake) | 15. Recoil starter handle |
| 5. Front handle (for left hand) | 16. Oil tank cap |
| 6. Back cover | 17. Clutch cover |
| 7. Choke knob | 18. Fixing nuts |
| 8. Primer | 19. Chain tension adjuster |
| 9. Throttle trigger lock-out | 20. Chain catcher |
| 10. Rear handle (for right hand) | 21. Spiked bumper |
| 11. Throttle trigger | |

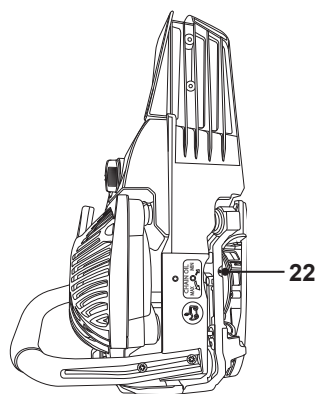

- 22. Chain oil flow adjuster
- 23. Main unit
- 24. Multi-tool

Content of delivery

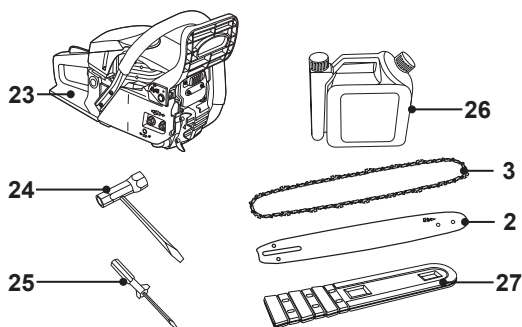

- 25. Screwdriver
- 26. Fuel mixing container
- 27. Guide bar cover

Technical specifications

General

- > **Dimensions:** approx. 48 x 26 x 30 mm
- > **Machine without guide bar, saw chain and empty tank:** approx. 5.4 kg
- > **Machine with guide bar, saw chain and empty tank, in normal operating configuration:** approx. 5.9 kg
- > **Fuel tank capacity:** 550 cm³ (550 mL)
- > **Petrol type:** #91 or higher, unleaded
- > **Engine oil type:** 2-stroke engine oil for air-cooled engines, high quality
- > **Fuel-oil ratio:** 40:1
- > **Lubrication oil capacity:** 260 cm³ (260 mL)
- > **Clutch engagement speed:** 4500 min⁻¹
- > **Cutting length:** 37.5 cm
- > **Guide bar brand / model:** Oregon / 160SDEA041
- > **Guide bar length:** 40 cm
- > **Saw chain gauge:** 1.27 mm (0.05")
- > **Saw chain brand / model:** Oregon / 91P057X
- > **Saw chain pitch:** 9.525 mm (3/8")
- > **Saw chain speed n_0 :** 26.7 m/s
- > **Drive sprocket:** 7 teeth x 9.525 mm

Engine

- > **Engine model:** 1E43F-2
- > **Engine type:** air cooled, 2-stroke engine
- > **Engine displacement:** 45.8 cm³
- > **Nominal power:** 1.6 kW
- > **Maximum operating engine speed (rotational frequency):** 12000 min⁻¹
- > **Idle speed:** 3000 min⁻¹
- > **Spark plug type:** L8RTF
- > **Spark plug gap:** 0.7 mm
- > **Carburetor brand / model:** Hualong / MC16A17 P

Sound emission level

- > **Sound pressure level at operator position:** 96.7 dB(A)
- > **Measured sound power level L_{WA} :** 106.6 dB(A)
- > **Uncertainty K:** 3 dB(A)
- > **Guaranteed sound power level L_{WA} (acc. to 2000/14/EC amended by 2005/88/EC):** 110 dB(A)

Vibration emission level

- > **Hand-arm vibration a_{hw} :** 8.0 m/s² (front); 6.4 m/s² (rear)
- > **Uncertainty K:** 1.5 m/s²

The sound values have been determined according to noise test code given in **EN ISO 11681-1**, using the basic standards **ISO 22868**.

Wear hearing protection, especially when sound pressure is over 80 dB(A).

The declared vibration value has been measured in accordance with a standard test method (according to **EN ISO 11681-1**) and may be used for comparing one product with another. The declared vibration value may also be used to evaluate the exposure for the user caused by vibration in advance.



WARNING! Depending on the actual use of the product the vibration values can differ from the declared total. Adopt proper measures to protect yourself against vibration exposures. Take the whole work process including times the product is running under no load or switched off into consideration! Proper measures include among others regular maintenance and care of the product and accessories, keeping hands warm, periodical breaks and proper planning of work processes!

Unpacking

1. Unpack all parts and lay them on a flat, stable surface.
2. Remove all packing materials and protective shipping materials, if applicable.
3. Make sure the delivery contents are complete and free of any damage. If you find that parts are missing or show damage do not use the product and contact your dealer. Using an incomplete or damaged product represents a hazard to operators and property.
4. Ensure that you have all the accessories and tools needed for assembly and operation. This also includes suitable personal protective equipment.



WARNING! The product and the packaging are not children's toys! Children must not play with plastic bags, sheets and small parts! There is a danger of choking and suffocation!

You will need

(items not supplied)

- > Suitable personal protective equipment
- > Sharpening set
- > Fuel funnel with filter
- > Suitable 2-stroke engine oil for air-cooled engines, high quality
- > Suitable fuel (unleaded petrol)
- > Container to collect fuel
- > First aid kit
- > Container to collect oil
- > Saw chain lubrication oil

(items supplied)

- > Multi-tool (24)
- > Screwdriver (25)
- > Fuel mixing container (26)

Assembly



WARNING! The product must be fully assembled before operation!



Do not use a product that is only partly assembled or assembled with damaged parts!

Follow the assembly instructions step-by-step and use the pictures provided as a visual guide to assemble the product easily!

Disconnect the spark plug connector before assembly! Reconnect it after assembly (see "Maintenance").



CAUTION: Risk of cuts!



The teeth of the saw chain are very sharp! Protective gloves must be worn for all work on the saw chain.



NOTE: Take care of small parts that are removed during assembly or when making adjustments. Keep them secure to avoid loss.

Installing the guide bar and saw chain



WARNING! Always use a saw chain designed as "low-kickback" or a saw chain which meets the low-kickback requirements! A standard saw chain (a chain which does not have the kickback reducing guard links) should only be used by an experienced professional operator! Nevertheless, a low-kickback saw chain does not completely eliminated kickback! A low-kickback or "safety" chain should never be regarded as complete protection against injury! Therefore always use a low-kickback saw chain in conjunction with other kickback protection devices such as the front hand guard!

1. Pull the front hand guard (4) backwards to disengage the chain brake (Fig. 1).

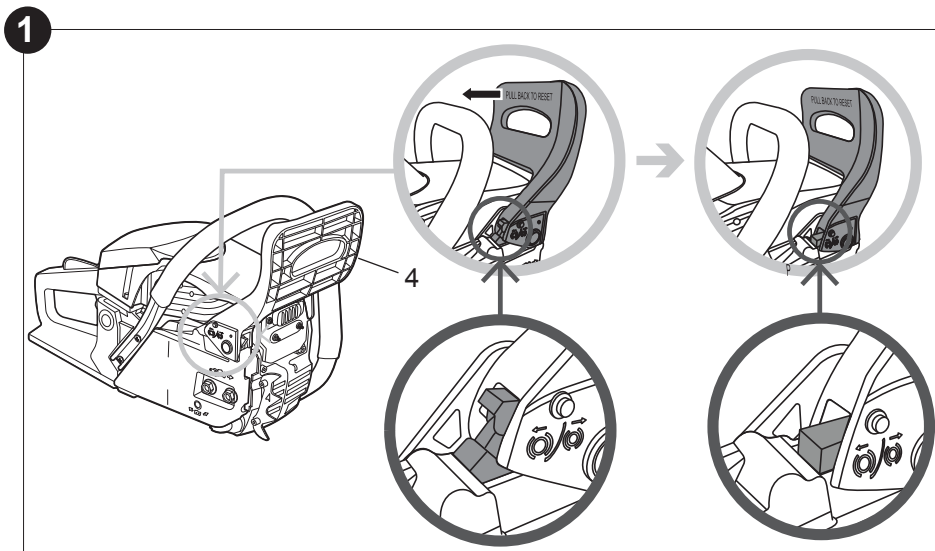

2. Unscrew the fixing nuts (18) using the multi-tool (24) and remove them together with the clutch cover (17) (Fig. 2).
Ensure the spiked bumper (21) is properly fixed to the product. Tighten the screws if necessary.

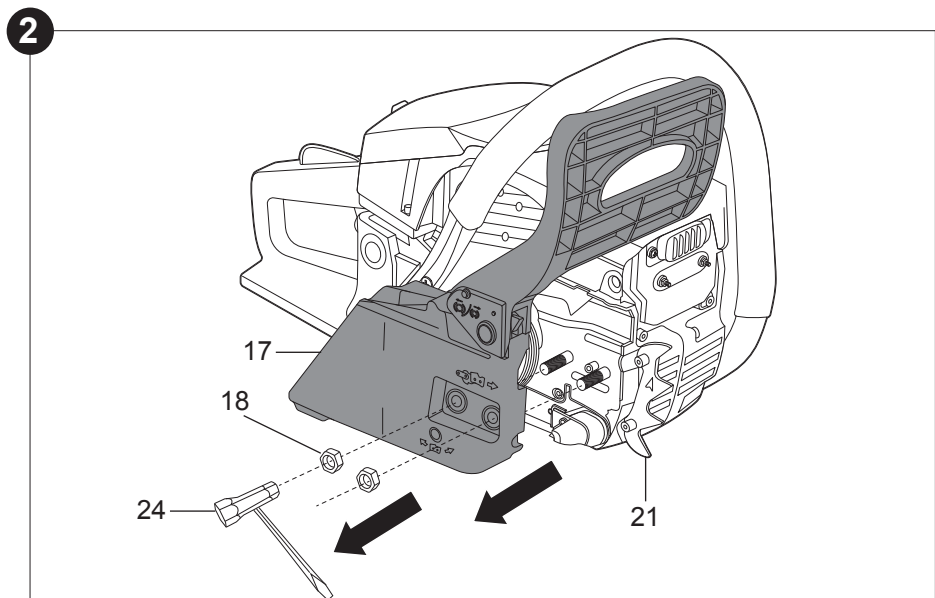

3. Place the slot on the guide bar (2) over the 2 bolts. Make sure to fit the guide bar with the saw chain "cutter" symbol at the top of the bar (step 1, Fig. 3).
4. Push the guide bar (2) to the left towards the drive sprocket (step 2, Fig. 3).



WARNING! The direction of the saw chain "cutters" must be as indicated by the symbol and arrow on the guide bar!

5. Place the saw chain (3) over the drive sprocket and fit around the guide bar (Fig. 4).

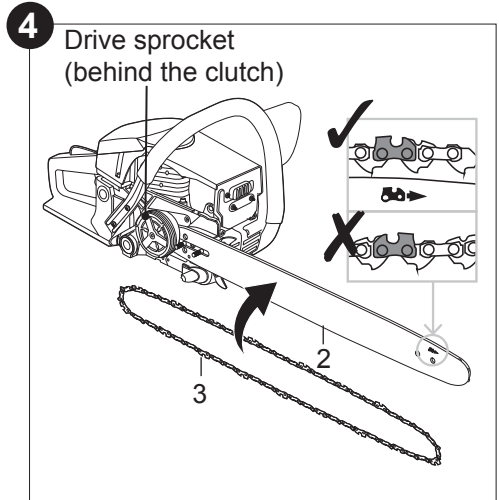
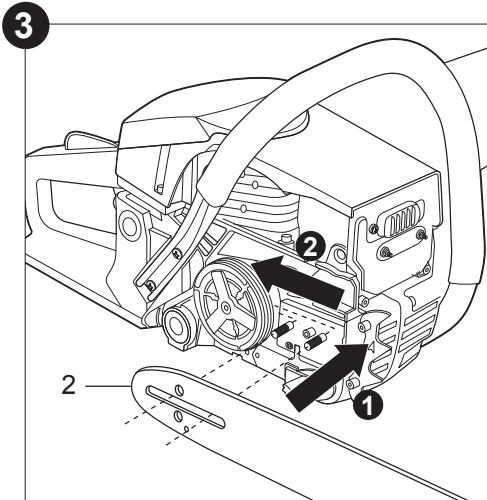

6. Pull the guide bar carefully towards the right to tighten the saw chain. Make sure the saw chain is placed above the chain catcher (20) (Fig. 5).

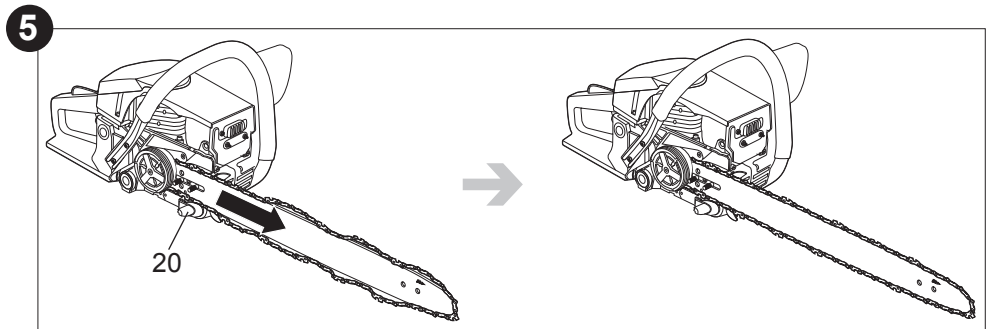

7. Refit the clutch cover (17) and fasten using the fixing nuts (18) and the multi-tool (24). To fit the clutch cover, align the tensioner pin with the lower hole on the guide bar by turning the chain tension adjuster (19) clockwise or anti-clockwise with the multi-tool (Fig. 6).



NOTE: Tighten the fixing nuts (18) finger tight only at this stage. The chain tension cannot be adjusted with the fixing nuts fully tightened.

6

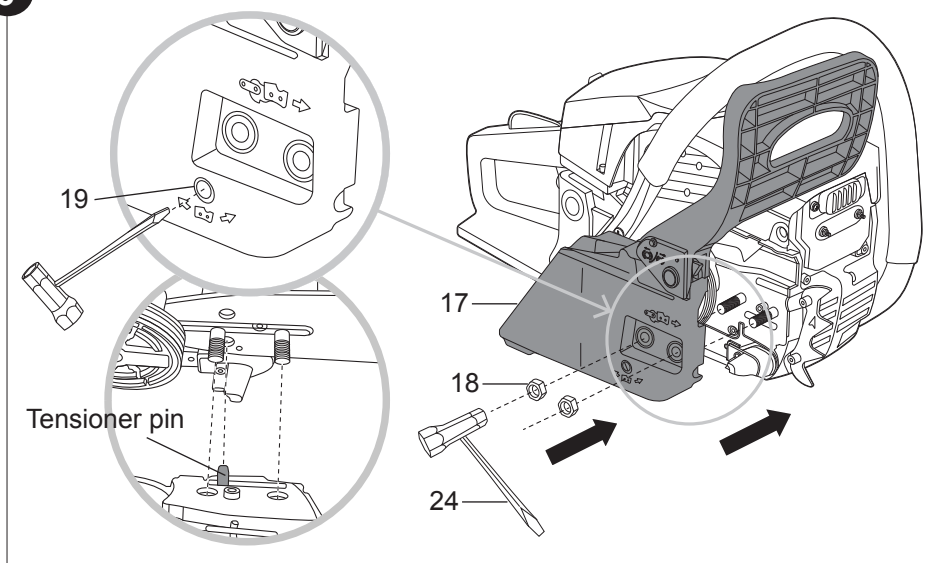

Tightening the saw chain

Always check the saw chain tension before use, after the first cuts and regularly during use, approx. every five cuts. Upon initial operation, new chains can lengthen considerably. This is normal during the break-in period and the interval between future adjustments will lengthen quickly.



WARNING! Disconnect the spark plug connector before adjusting saw chain tension!



The cutting edges of the saw chain are sharp! Always wear protective gloves when handling chain!



Always maintain proper chain tension! A loose chain increases the risk of kickback! A loose chain may jump out of the guide bar groove! This may injure the operator and damage the chain! A loose chain will cause rapid wear to the chain, guide bar and the drive sprocket! Tensioning the chain too tightly will overload the engine and cause damage, and insufficient tension can cause chain derailing, whereas a correctly tightened chain provides the best cutting characteristics and prolonged working life! The chain life mainly depends upon sufficient lubrication and correct tensioning!

1. Lift the tip of the guide bar (2) up and hold for adjusting the chain tension (Fig. 7).
2. Turn the chain tension adjuster (19) until the saw chain (3) is tight around the guide bar (Fig. 8).

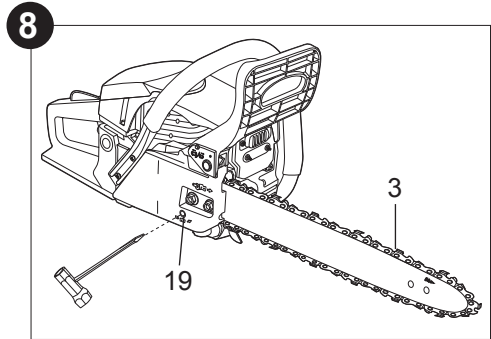
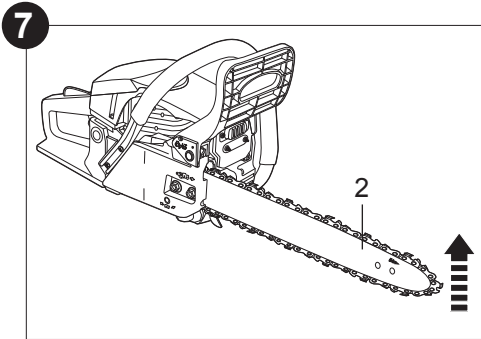

3. Adjust the tension. It should be possible to lift up the saw chain 3-4 mm from the guide bar (Fig. 9).

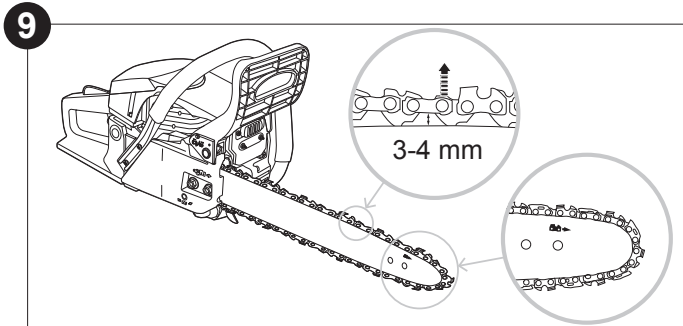

4. Tighten the fixing nuts (18) to secure the guide bar and the clutch cover.

Switching between standard/winter operation

Set the vent for the carburettor to standard or winter operation mode. In winter operation mode the vent is open so that the hot air from around the cylinder can flow to the carburettor. This prevents the carburettor from freezing.

1. Pull the locking lever on the back cover and remove the back cover (6).
2. Remove the ventilation cover (6a) and place it in a proper direction (Fig. 10).

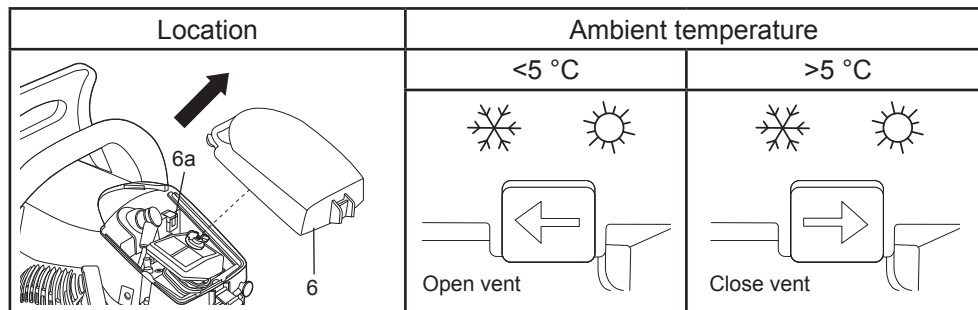

3. Refit the back cover and secure it with the locking lever.

Chain lubrication



WARNING! The product is not filled with chain oil. It is essential to fill the product with chain oil before using it! Never operate the product without chain oil as this will result in extensive damage to the product! Operating the saw chain dry or with too little chain oil will decrease cutting efficiency, shorten the product life span and cause rapid wear to the saw chain and guide bar from overheating! Insufficient chain oil is evident by smoke or bar discoloration! Adequate lubrication of the saw chain during cutting operations is essential to minimise friction with the guide bar (2).

1. Place the product on a stable, level surface with the oil tank cap (16) facing upwards. We recommend laying a non-flammable sheet under the product.
2. Unscrew and remove the oil tank cap (16) (Fig. 11).
3. Fill suitable saw chain oil into the tank using a funnel fitted with a filter to avoid debris entering the tank. Do not overfill and leave approximately 5 mm of space between the top of the oil and the inside edge of the tank to allow for expansion (Fig. 12).



NOTE: Use lubricant oil SAE#10W-30 all year round or SAE#30-#40 in summer and SAE#20 in winter.



NOTE: Towards the end of the season, it is advisable to put only as much lubricant in the tank as you need for each cut, so that it is completely used up before you store the product.

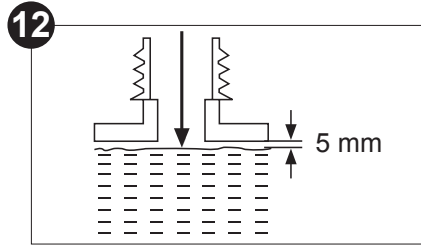
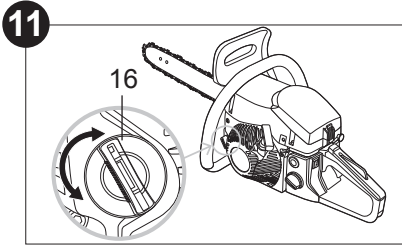

4. Wipe up spilled saw chain oil with a soft cloth. Refit and screw the oil tank cap firmly (Fig. 11).



NOTE: Always dispose of used saw chain oil and objects contaminated with them in accordance with local regulations.

Test run



NOTE: Perform the following test before operating your product. This product is equipped with an automatic oiling system! The oiling system automatically delivers the proper amount of oil to the guide bar and saw chain. Checking the lubrication requires starting the engine. Before checking, the product must be fully assembled and all instructions must have been read.

1. Make sure the guide bar (2) and the saw chain (3) are in place when you check the oil delivery.
2. Start the engine; keep it running at medium power and check if the chain oil is delivered as shown (Fig. 13).
3. Adjust the chain oil flow by turning the chain oil flow adjuster (22) on the bottom of the product using the screwdriver (25) (Fig. 14).

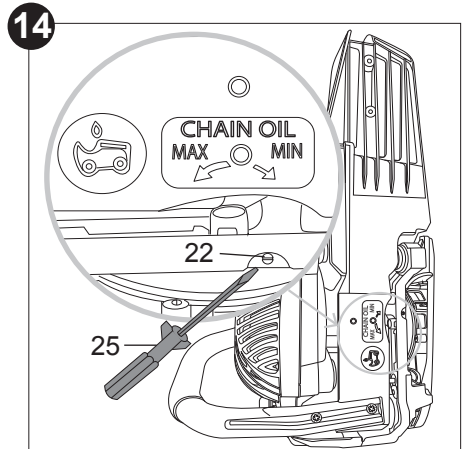
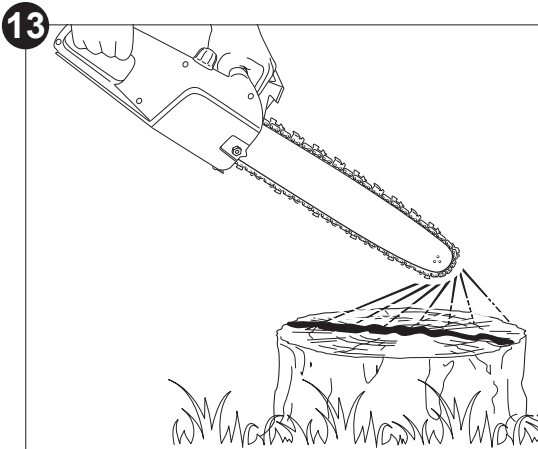

Filling up fuel and oil



WARNING! This product is not supplied with petrol-oil mixture in the engine! Before operating this product it is essential to fill it with petrol-oil mixture!

This product is equipped with a 2-stroke engine, the fuel and oil tank are combined and it is essential to fill a fuel-oil mixture before operating this product. Observe the technical specifications for suitable fuel and engine oil.



WARNING! Fuel and oil are highly inflammable! Fumes will explode if lit! Ensure that there are no naked flames around the product! Do not smoke while filling fuel and oil!







NOTE: To avoid spillage and to filter out debris, use a funnel with filter to fill the container and the oil tank.

1. Place the product on a stable, level surface with the fuel tank cap (13) facing upwards. We recommend laying a non-flammable sheet under the product.
2. Pour a regular-grade unleaded petrol and a quality engine oil for air cooled 2-stroke engines in the supplied fuel mixing container (26) respectively via the 2 openings. Use the scale markings on different sides for your desired ratio for petrol:oil. For example, this indicates a correct ratio of 40:1 when using the scale 40:1.
3. Tilt and shake the container thoroughly to make the fuel.



NOTE: Use an anti-oxidant added quality oil expressly labelled for air-cooled 2 stroke engine use (JASO FC GRADE OIL or ISO EGC GRADE). Do not use BIA or TWC (2 stroke water-cooling type) mixed oil. The recommended mixing ratio for petrol:oil is 40:1.

NOTE: Never mix fuel and oil directly in the tank of the product.

| | | | | |
|---|---|---|---|---|
|  |  |  |  |  |
| 100 ml | + | 2.5 ml | = | 40:1 |
| 200 ml | + | 5 ml | = | |
| 300 ml | + | 7.5 ml | = | |
| 400 ml | + | 10 ml | = | |

4. Unscrew and remove the fuel tank cap (13) (Fig. 15).
5. Fill the fuel into the fuel tank. Leave approximately 5 mm of space between the top of the fuel and the inside edge of the tank to allow for expansion. Do not overfill (Fig. 16).
6. Wipe up spilled fuel with a soft cloth. Refit and screw the fuel tank cap firmly (Fig. 15).

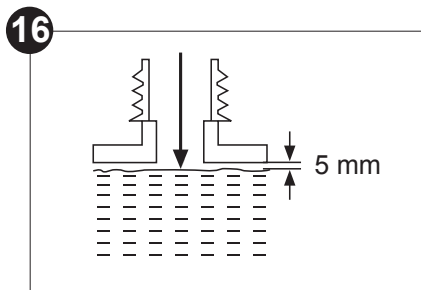
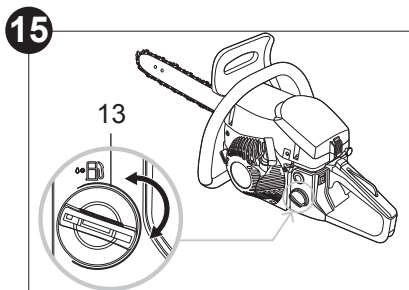

NOTE: Fuel and oil deteriorate over time. It may be difficult to start the engine if you use fuel which has been kept for more than 30 days. Towards the end of the season, it is advisable to put only as much fuel in the tank as you need for each use, since it should be completely used up before storing the product. Empty remaining fuel from the tank when storing the product for over 30 days.

Operating controls

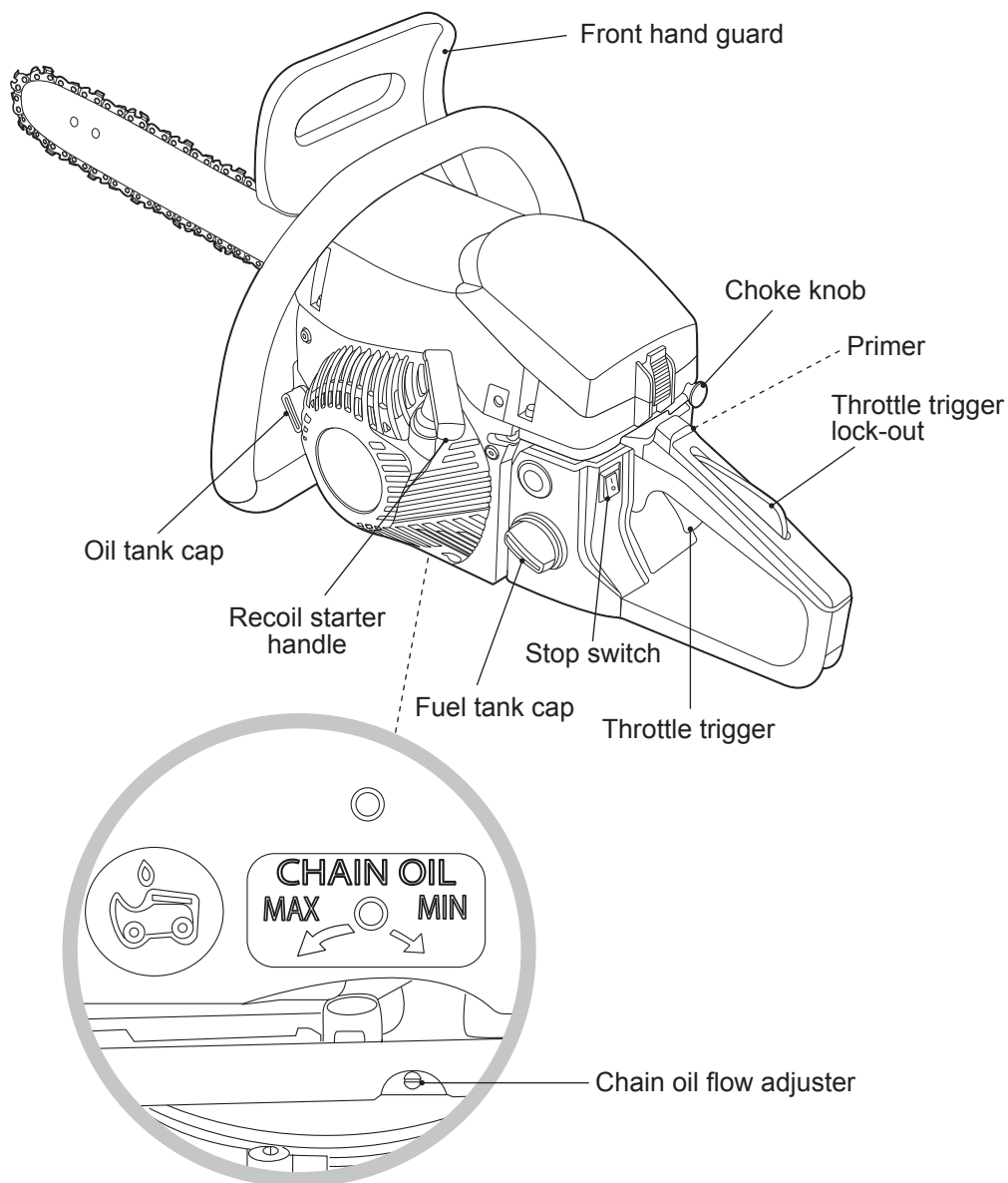

Preparation



Assemble



Adjust



Add fuel and oil mixture



Add chain oil

Starting



1 Engage the chain brake



2 Set stop switch to I



3 Press primer 8 times



4 Fully pull choke knob



5 Pull recoil starter handle 4 times



6 Full press in choke knob

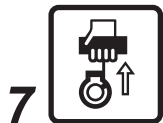

7 Pull recoil starter handle until engine starts

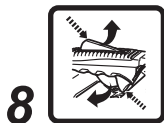

8 Press and release throttle trigger and interlock



9 Run idle for 15 seconds



10 Disengage chain brake



11 Operate

$= 1+2+4+6+7+8+10+11$

If the engine is warm skip steps 3 and 5

Stopping



Release throttle trigger and interlock



Engage the chain brake



Set stop switch to **O**

Storage



Empty fuel tank



Empty oil



Clean and maintain



Store



WARNING! This quick start provides only a short overview of how to start and stop the product! For safe use it is essential to read the entire instruction manual before first use!

Intended use

This petrol chain saw FPCSP46-2 is designated with a power output of 1.6 kW. The product is intended for cutting logs and limbs with a thickness of max. 37.5 cm (see "Technical specifications").



WARNING! The product may be used by an experienced operator* having read and understood the safety requirements provided within this instruction manual using appropriate personal protective equipment (PPE)!

This product must not be used for cutting other materials, such as plastic, stone, metal, wood that contains foreign objects, or materials that are harmful to health. This product should not be used outside of domestic premises e.g. for cutting firewood in forested areas. The product may only be used with the guide bar/saw chain combination stated within these instructions. The use of other types or sizes is not allowed, because it can result in serious personal injury or death.

For safety reasons it is essential to read the entire instruction manual before first operation and to observe all the instructions therein. This product is intended for private domestic use only, not for any commercial trade use. It must not be used for any purposes other than those described.

* A trained operator is a person who has the competence and knowledge in the use and hazards associated with using a chain saw as well as the precautions to be taken to limit these hazards.

Safety equipment

The product has several pieces of safety equipment which reduce the risk of injury when working (Fig. 17):

17

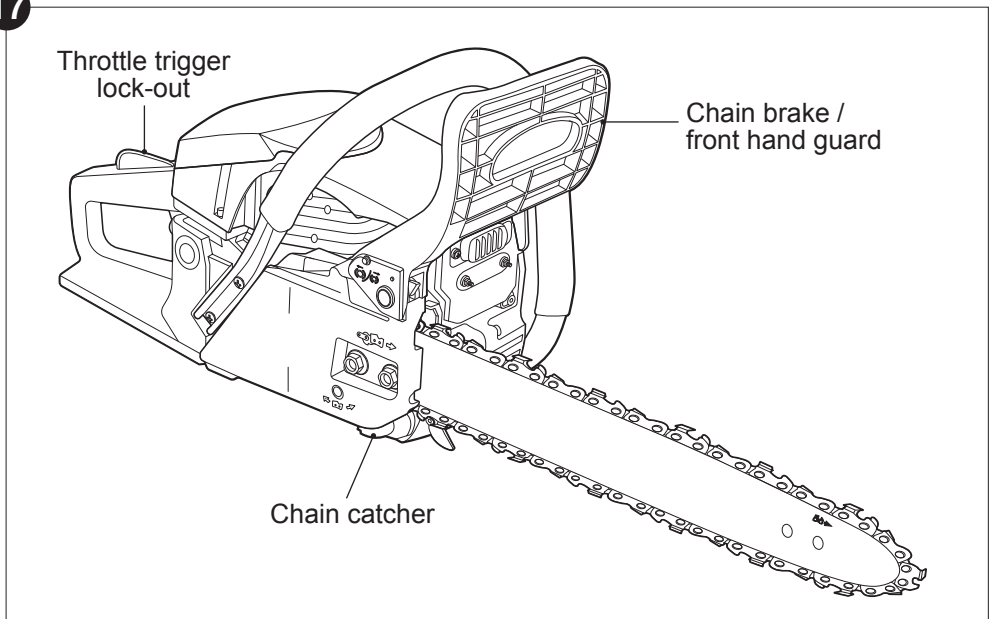

Chain brake / front hand guard

The front hand guard (4) is a safety mechanism that stops the saw chain (3) immediately when it is pushed towards the operator in case of a kickback.

The chain brake is a safety mechanism activated by the front hand guard (4). When kickback occurs, the saw chain stops immediately.

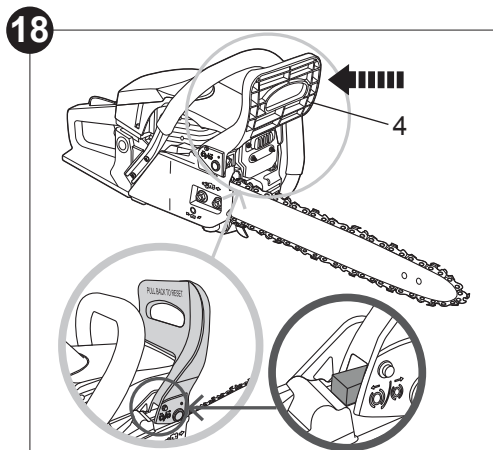

The chain brake in the disengaged position, the product can be operated (Fig. 18).

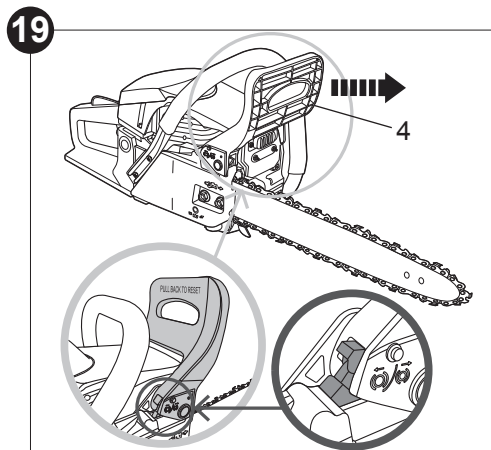

The chain brake in the engaged position, the saw chain is stopped as soon as the chain brake is activated (Fig. 19).

Chain brake test– manual chain brake

The following function check should be carried out before each use. The purpose of the chain brake testing is to reduce the possibility of injury due to kickback.

1. Start the product as described below.
2. Press the throttle trigger lock-out (9), then fully press the throttle trigger (11) with your index finger and hold in this position.
3. While the engine is running, activate the chain brake by rolling your left hand forward against the front hand guard (4). Saw chain (3) should stop immediately.



WARNING! If the saw chain fails to stop when the chain brake is engaged, take the product to the nearest authorised service centre or a similarly qualified person! Do not use the product if the chain brake is not in working properly!

Chain brake test – non-manual chain brake

The non-manual chain brake stops the operation of the saw chain in such a manner that the kickback action produced at the end of the guide bar non-manually engages the chain brake.

To make sure that the non-manual chain brake operates properly, proceed as follows:

1. Stop the engine of the product.
2. Position a flat piece of wood beneath the chain saw.
3. Hold the front and rear handles with hands (grip them lightly), so that the guide bar may be placed at the height of about 55 cm (Fig. 20).

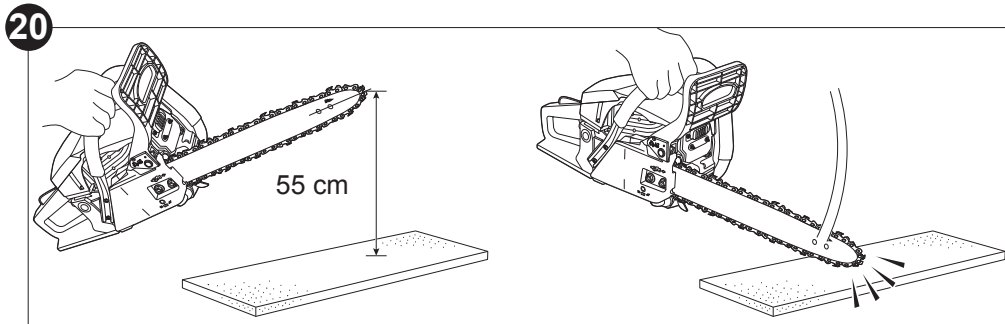

4. Slowly release the left hand from the front handle, allowing the end of the guide bar to touch against the wood so that the product receives an impact (at this time the rear handle should be gripped lightly with right hand).
5. The impact is transferred to the brake lever, which engages the chain brake.

Throttle trigger lock-out

The throttle trigger lock-out (9) prevents unintentional activation of the throttle trigger (11). The throttle trigger can only be activated if the throttle trigger lock-out is pressed.

Chain catcher

The chain catcher (20) is intended to catch a torn saw chain (3) or saw chain which has jumped out of the guide bar. Through regular maintenance of the guide bar and correct and regular tensioning of the saw chain, accidents of this type can be prevented.



DANGER! Risk of injury! The product must only be put into operation if no faults are found. If any safety equipment is defective, it must absolutely be replaced before the next use.

Operation

Check before starting:

1. Check the product, as well as accessories for damage before each use. Do not use the product if it is damaged or shows wear.
2. Double check that accessories and the guide bar/saw chain are properly fixed.
3. Check the fuel level and chain oil level, refill if necessary.
4. Always hold the product by its handles. Keep the handles dry and clean to ensure safe support.
5. Ensure that the air vents are always unobstructed and clear. Clean them if necessary with a soft brush. Blocked air vents may lead to overheating and damage the product.
6. Stop the engine immediately if you are disturbed while working by other people entering the working area. Always let the product come to complete stop before putting it down.
7. Do not overwork yourself. Take regular breaks to ensure you can concentrate on the work and have full control over the product.



NOTE: In some countries regulations define at what time of the day and on what special days products are allowed to be used and what restrictions apply! Ask your community for detailed information and observe the regulations in order to preserve a peaceful neighbourhood and avoid committing administrative offenses!

Starting the engine



DANGER! Risk of fire!

- > Due to any spilled fuel, the product can catch fire.
- > Wipe any spilled fuel up before starting.
- > Start the engine a few metres away from the place where you have filled it.



DANGER! Risk of injury! If the chain brake is not engaged, the saw chain starts up directly after the engine is started. Make sure the chain brake is engaged before starting the engine!



NOTE: Risk of product damage!

Never twist the starter cord around your hand! Only pull on the handle!

Do not suddenly release the recoil starter handle! Allow the rope to return slowly and in a controlled manner each time it is pulled!

Engine cold start

1. Place the saw where it does not come into contact with any objects.
2. Engage the chain brake.
3. Set stop switch (12) to I (Fig. 21).
4. Press the primer (8) until the bubble is filled with fuel (6-8 times) (Fig. 22).
5. Pull out the choke knob (7) (Fig. 23).

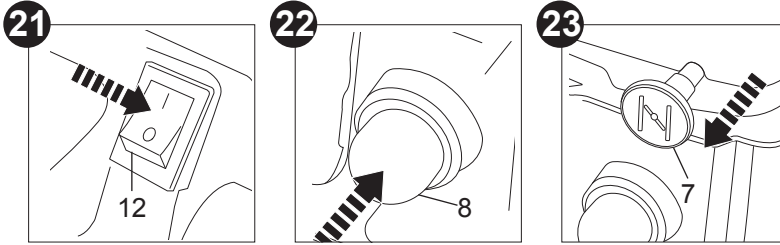

6. Hold the product securely to the ground. Place your left hand on the front handle (5) and additionally secure it with your right foot (Fig. 24).
7. Pull the recoil starter handle (15) slowly with your right hand until you feel a definite resistance and then give it a brisk, strong pull. Repeat until the engine attempts to start but no more than 4 times.
8. Press in the choke knob (7) fully.
9. Pull the recoil starter handle (15) briskly and strongly. Repeat until the engine starts.
10. Squeeze the throttle trigger lock-out (9) and throttle trigger (11) and release them.
11. Let the product run in idle for 10 to 15 seconds to let it warm up.
12. Push the front hand guard (4) to check if the chain brake works properly. Then disengage the chain brake.
13. To start cutting, grip the product with both hands, left hand holding the front handle (5) (do not hold the front hand guard) and the right hand holding the rear handle (10).

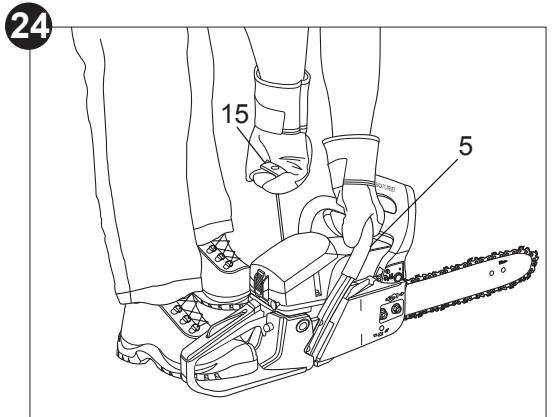

Engine warm start

1. Place the saw where it does not come into contact with any objects.
2. Engage the chain brake.
3. Set stop switch (12) to **I** (Fig. 25).
4. Pull out the choke knob (7) fully and then press in back in fully (Fig. 26).

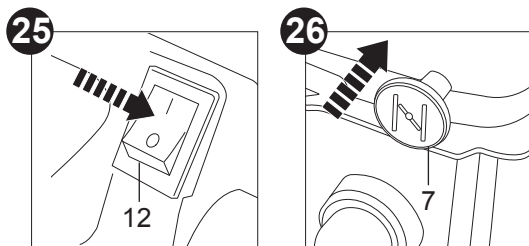

5. Hold the product securely to the ground. Place your left hand on the front handle (5) and additionally secure it with your right foot (Fig. 24).
6. Pull the recoil starter handle (15) briskly and strongly. Repeat until the engine starts.
7. Squeeze the throttle trigger lock-out (9) and throttle trigger (11) and release them.
8. Push the front hand guard (4) to check if the chain brake works properly. Then disengage the chain brake.
9. To start cutting, grip the product with both hands, left hand holding the front handle (5) (do not hold the front hand guard) and the right hand holding the rear handle (10).

After starting the engine

1. Leave the engine running at idling speed for a while.
2. Slowly press down on the throttle trigger (11) to increase the engine speed.

The clutch will be released when the engine speed is high enough, and the saw chain (3) will start to rotate.

3. Make sure the saw chain is sufficiently lubricated.
4. Check if the saw chain stops rotating when you release the throttle trigger.

Stopping the engine

1. Release the throttle trigger (11) and let the product run in idle for a while.
2. Engage the chain brake.
3. Set stop switch (12) to **O**.



WARNING! The product continues to work for some time even after the engine has been stopped! Wait until it comes to a complete stop before you put the product down!

Basic operating / cutting procedure

1. To become proficient attend a recognised chain saw training course to learn how to operate chain saws safely and effectively. Familiarise yourself with all the controls and switches. Practise all movements with the product switched off.
2. Always hold the product firmly with both hands. Front handle (5) with the left hand and rear handle (10) with the right hand. Fully grip both handles at all times during operation. Never operate the product using only one hand.
3. Only use the product with a secure stance. Hold the product at the right-hand side of your body (Fig. 27).

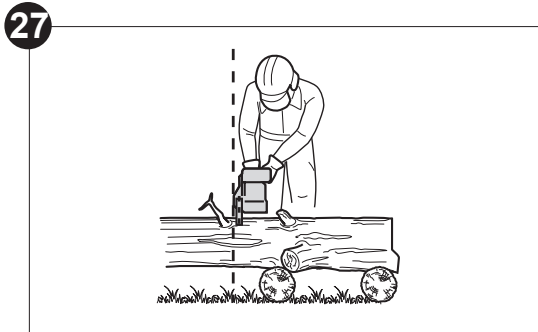

4. Check the proper lubrication as described in section "Before you start - Chain lubrication" before performing any cut.
5. Ensure the saw chain (3) is running at full speed before it makes contact with the wood. Use the spiked bumper (21) to secure the product onto the wood before starting to cut and use it as a leverage point while cutting (Fig. 28).

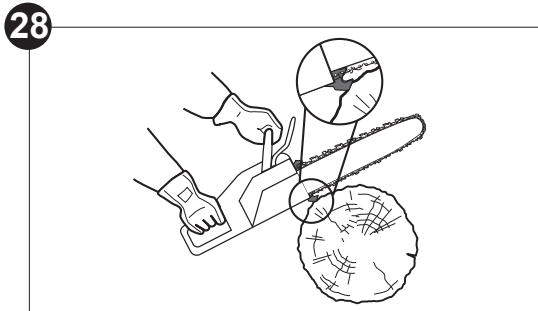

6. Reset the spiked bumper at a low point when cutting thicker logs by pulling the product slightly backwards until the gripping teeth release, and reposition at lower level to continue sawing. Do not remove the product completely from the wood.
7. Do not force the saw chain while cutting, let the chain do the work, using the gripping teeth to apply minimal leverage pressure.

8. Do not operate the product with arms fully extended or attempt to saw areas which are difficult to reach, or on a ladder. Never use the product above shoulder height (Fig. 29).

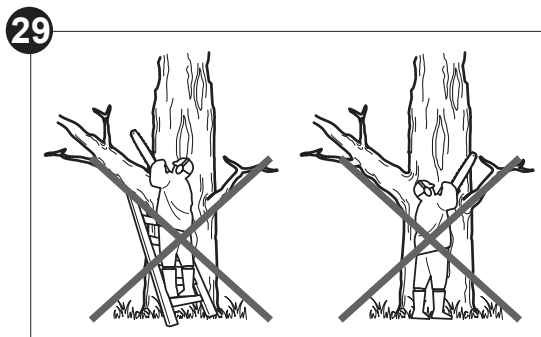

9. Optimum sawing is achieved if the chain speed remains constant during cutting.
 10. Be careful when reaching the end of the cut. The weight of the product may change unexpectedly as it cuts free from the wood. This can cause accidents to the legs and feet. Always remove the product from a wood cut while the product is running.
 11. Check that the oil feed to the chain is operating correctly; run the chain saw at medium speed and ensure that the chain has received a consistent coating of oil.

Kickback



WARNING! Beware of kickback! Kickback can lead to dangerous loss of control of the product and result in serious or fatal injury to the operator or anyone standing close by! Always be alert because rotational kickback and pinch kickback are major product operational dangers and the leading cause of most accidents!



Kickback may occur if the nose or tip of the guide bar touches an object, or if wood pinches the saw chain in the cut. In some cases, contact with the tip of the guide bar (2) may cause a lightning-fast reverse reaction, kicking the guide bar up and back toward the operator (Fig. 30).

30

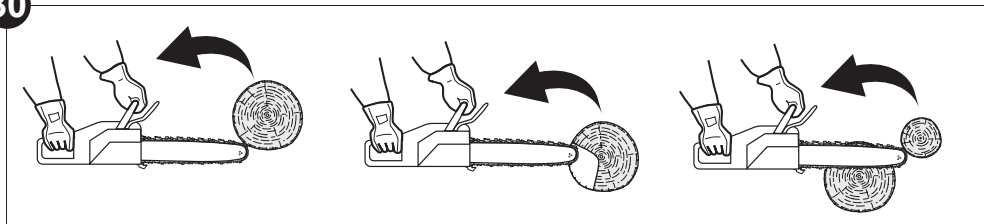

1. Pinching the saw chain (3) along the bottom of the guide bar (2) may pull the product forward away from the operator (“skating”) (Fig. 31).
2. Pinching the saw chain along the top of the guide bar may push the guide bar rapidly back toward the operator (“bouncing”) (Fig. 32).

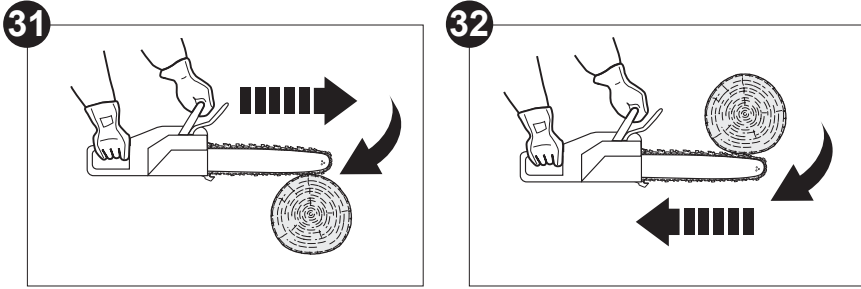

3. Any of these reactions may cause losing control of the product, which could result in serious personal injury or even death.
4. With a basic understanding of “kickback”, the element of surprise can be reduced or eliminated. Sudden surprise contributes to the majority of accidents.
5. Keep a good firm grip on the product with both hands, the right hand on the rear handle (10) and the left hand on the front handle (5), when the engine is running. Maintain a firm grip with your thumbs and fingers encircling the handles. A firm grip will help you reduce “kickback” and maintain control of the product.
6. You should carefully read all safety warnings and user instructions before attempting to operate this product.

To avoid kickback:

1. Saw with guide bar at a flat angle.
2. Never work with a loose, widely stretched or the heavily worn out chain.
3. Ensure chain is sharpened correctly.
4. Never saw above shoulder height.
5. Never work with the tip of the guide bar.
6. Always hold the product firmly with both hands.
7. Always use a low kickback chain.
8. Apply the metal gripping teeth for leverage.
9. Ensure correct chain tension.
10. Do only cut with the engine at high speeds.
11. Do not let the nose of the guide bar contact a log, branch, or any other obstruction which could be hit while you are operating the product.
12. Follow manufacturer’s sharpening and maintenance instructions for the saw chain.
13. Only use replacement guide bars and saw chains specified by the manufacturer or equivalent replacements.



WARNING! Most “kickback” accidents happen during limbing! Pay close attention to the position of the ‘kickback’ zone of the bar when you are “limbing branches that are under tension.



Felling a tree

1. When bucking and felling operations are being performed by two or more persons at the same time, the felling operations should be separated from the bucking operation by a distance of at least twice the height of the tree being felled. Trees should not be felled in a manner that would endanger any person, strike any utility line or cause any property damage. If the tree does make contact with any utility line, the company should be notified immediately.
2. The product operator should keep on the uphill side of the terrain as the tree is likely to roll or slide downhill after it is felled.
3. An escape path should be planned and cleared as necessary before cuts are started. The escape path should extend back and diagonally to the rear of the expected line of fall (Fig. 33).
4. Before felling is started, consider the natural lean of the tree, the location of larger branches and the wind direction to judge which way the tree will fall.
5. Remove dirt, stones, loose bark, nails, staples and wire from the tree.

33

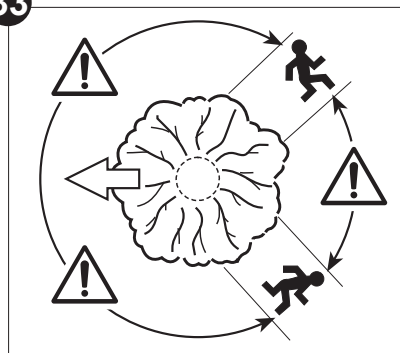

Notching undercut

Make the notch (Fig. 34, B) 1/3 the diameter of the tree, perpendicular to the direction of falls (Fig. 34). Make the lower horizontal notching cut first. This will help to avoid pinching either the saw chain or the guide bar when the second notch is being made.

34

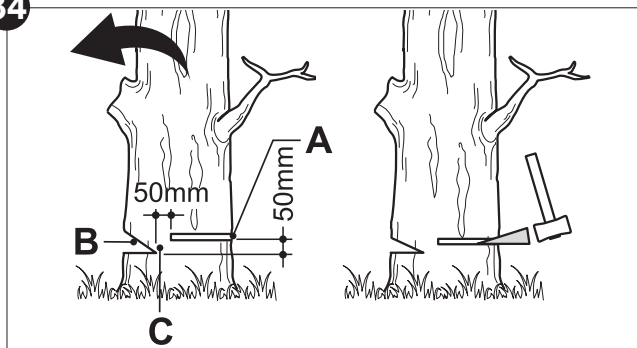

Felling back cut

1. Make the felling back cut (Fig. 34, A) at least 50 mm higher than the horizontal notching cut (Fig. 34). Keep the felling back cut parallel to the horizontal notching cut. Make the felling back cut so enough wood is left to act as a hinge. The hinge (Fig. 34, C) wood keeps the tree from twisting and falling in the wrong direction. Do not cut through the hinge.
2. As the felling gets close to the hinge, the tree should begin to fall. If there is any chance that the tree may not fall in desired direction or it may rock back and bind the saw chain, stop cutting before the felling back cut is complete and use wedges of wood, plastic or aluminium to open the cut and drop the tree along the desired line of fall.
3. When the tree begins to fall remove the product from the cut, stop the engine, put the product down, then use the retreat path planned. Be alert for overhead limbs falling and watch your footing.

Limbing and pruning

Limbing is removing the branches from a fallen tree. When limbing leave larger lower limbs to support the log off the ground. Remove the small limbs in one cut (Fig. 35). Branches under tension should be cut from the bottom up to avoid binding the product.

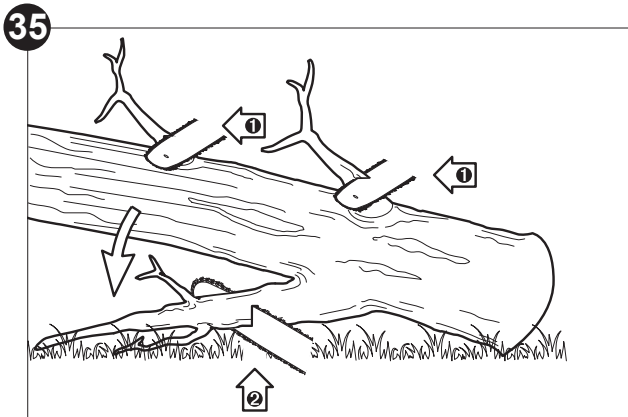

WARNING! Never climb into a tree to limb or prune! Do not stand on ladders, platforms, logs, or in any position which may cause you to lose the balance or control of the saw! When pruning trees, it is important not to make the flush cut next to main limb or trunk until you have cut off the limb further out to reduce the weight! This prevents stripping the bark from the main member!



WARNING! If the limbs to be pruned are above chest height, hire a professional to perform the pruning!

Cutting spring poles

A spring pole is any log, branch, rooted stump, or sapling which is bent under tension by other wood so that it springs back if the wood holding it is cut or removed.

On a fallen tree, a rooted stump has a high potential of springing back to the upright position during the bucking cut to separate the log from the stump. Watch out for spring poles, they are dangerous.

Bucking a log

Bucking is cutting a log into lengths. It is important to make sure your footing is firm and your weight is evenly distributed on both feet. When possible, the log should be raised and supported by the use of limbs, logs or chocks.

1. Follow the simple directions for easy cutting. When the log is supported along its entire length (Fig. 36), it is cut from the top (overbuck).
2. When the log is supported on one end (Fig. 37), cut $\frac{1}{3}$ the diameter from the underside (underbuck). Then make the finished cut by overbucking to meet the first cut.

36

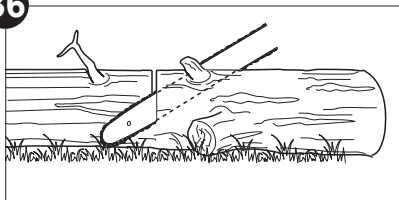

37

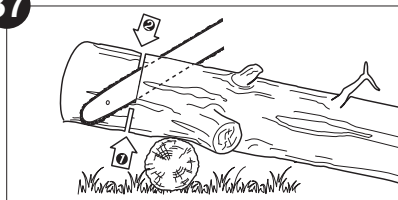

3. When the log is supported on both ends (Fig. 38), cut $\frac{1}{3}$ the diameter from the top (overbuck). Then make the finished cut by underbucking the lower $\frac{2}{3}$ to meet the first cut.
4. When bucking on a slope always stand on the uphill side of the log (Fig. 39). When “cutting through”, to maintain complete control release the cutting pressure near the end of the cut without relaxing your grip on the product handles. Do not let the chain contact the ground. After completing the cut, wait for the saw chain to stop before you move the product. Always stop the engine before moving from tree to tree.

38

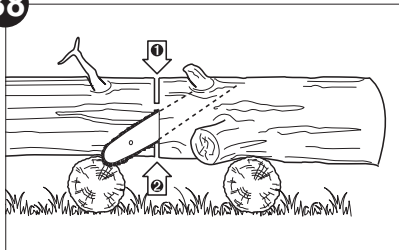

39

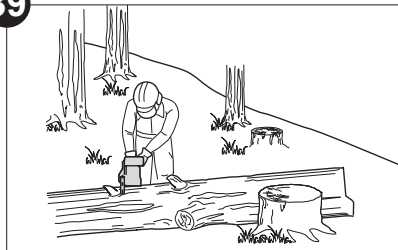

5. Support small logs on a sawing stand or another log while bucking (Fig. 40).
6. If the wood diameter is large enough for you to insert a soft bucking wedge without touching the chain, you should use the wedge to hold the cut open to prevent pinching (Fig. 41).

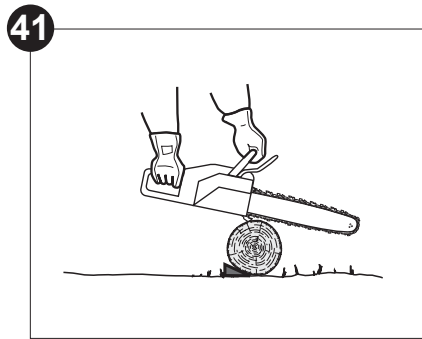
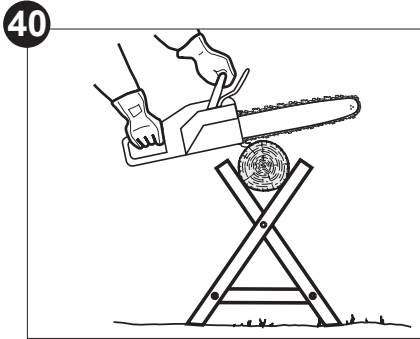

Freeing a trapped saw

If the saw becomes trapped during cutting, operators should

- a) switch off the saw and attach it securely to the tree inboard (i.e. towards the trunk side) of the cut or to a separate tool line,
- b) pull the saw from the kerf while lifting the branch as necessary, and
- c) if necessary, use a handsaw or second chain saw to release the trapped saw by cutting a minimum of 30 cm away from the trapped saw.

Whether a handsaw or a chain-saw is used to free a trapped saw, the release cuts should always be outboard (toward the tips of the branch), in order to prevent the saw being taken with the section and further complicating the situation.

Regardless of whether a handsaw or a chain saw is used to release a jammed chain saw, the cuts to release the chain saw should always be made on the outside (towards the branch tips) in order to ensure that the chain saw does not fall along with the sawn off parts and make the situation even more complicated.

After use

1. Stop the engine, disconnect the spark plug connector and let it cool down.
2. Check, clean and store the product as described below.

The golden rules for care



WARNING! Always stop the engine, disconnect the spark plug connector and let the product cool before performing inspection, maintenance and cleaning work.



DANGER! Proper maintenance is essential for safe and trouble free operation. Improper maintenance, or failure to address a problem instantly can cause a malfunction which can result in serious injury or even death.

1. Keep the product clean. Remove debris after each use and before storage.
2. Regular and proper cleaning helps to ensure safe operation and prolongs the life of the product.
3. Inspect the product before each use for worn and damaged parts. Do not operate it if you find broken and worn parts. Replace worn parts as necessary or contact an authorised service centre for repair before using the product again.



WARNING! Only perform repairs and maintenance work according to these instructions! All further works must be performed by a qualified specialist!

Cleaning



NOTE: Do not use chemical, alkaline, abrasive or other aggressive detergents or disinfectants to clean this product as they might be harmful to its surfaces.

Cleaning the housing

- > Use a damp, lint-free cloth to clean the housing of the product.
- > Do not immerse the product into water or any liquids.
- > Clean the ventilation slots on the bottom and at the side cover of the engine with a soft brush. Clogged ventilation slots might cause the engine to overheat.
- > Wipe the surface with a dry cloth afterwards.

Cleaning the saw chain

- > Use a soft plastic brush to clean the saw chain (3) from dirt.
- > Use a resin solvent (not provided) to clean the saw chain. Read the resin solvent manufacturer's instructions before proceeding.
- > To protect the saw chain from rust and oxidation, lubricate it with a special saw chain oil (not provided).

Cleaning the guide bar

- > Disassemble the guide bar (2) and saw chain in reversed order from assembly.
- > Remove any dirt accumulated inside the guide bar slot using the putty knife (not provided) (Fig. 42).
- > Use a damp, lint-free cloth to clean the surface.
- > Wipe the surface with a dry cloth afterwards.

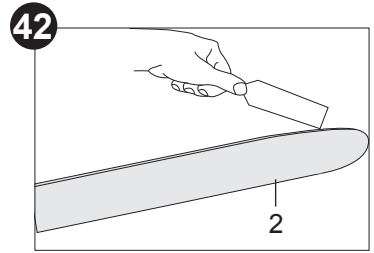

Maintenance table

Inspect and maintain this product regularly based on below maintenance table. Keep the chain saw in good working condition during maintenance.

| Part | Task | Before/after each use | Every 10 hours of operation | Every 25 hours of operation |
|---------------|-----------|-----------------------|-----------------------------|-----------------------------|
| Cylinder fins | clean | | X | |
| | check | | | X |
| Spark plug | clean | | | X |
| | replace | | whenever necessary | |
| Air filter | check | X | | |
| | clean | | X | |
| | replace | | whenever necessary | |
| Fuel filter | clean | | whenever necessary | |
| | replace | | whenever necessary | |
| Saw chain | check | X | | |
| | lubricate | X | | |
| | clean | X | | |
| | replace | | whenever necessary | |

Chain catcher

Replace a damaged or worn chain catcher (20) with a new one of the same type.

1. Loosen the screw of the chain catcher and remove it.
2. Fix a new chain catcher to the product.

Sprocket wheel

1. Clean the sprocket wheel.
2. Using a disposable lube gun, insert the needle nose into the lubrication hole (1) and inject grease until it appears at the outside edge of the sprocket (Fig. 43).
3. Make sure that the chain brake is disengaged. Rotate the saw chain (3) by hand. Repeat the lubrication procedure until the entire sprocket has been greased.

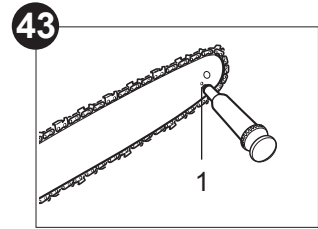

Guide bar and saw chain maintenance

Most guide bar problems can be prevented merely by keeping the product well maintained. Incorrect filing and non-standard cutter and depth gauge settings are the causes of most guide bar problems, primarily resulting in uneven bar wear. As the bar wears unevenly, the rails widen, which may cause the chain to clatter and make it difficult to complete straight cuts. If the guide bar is insufficiently lubricated and the product is operated with a saw chain which is too tight, this will contribute to rapid bar wear. To help minimise bar wear, maintenance of the guide bar as well as the saw chain is recommended.

1. Disassemble the guide bar and saw chain in reversed order from assembly.
2. Check the oiling port for clogging and clean if necessary to ensure proper lubrication of the guide bar and saw chain during operation. Use a soft wire small enough to insert into the oil discharge hole (Fig. 44).

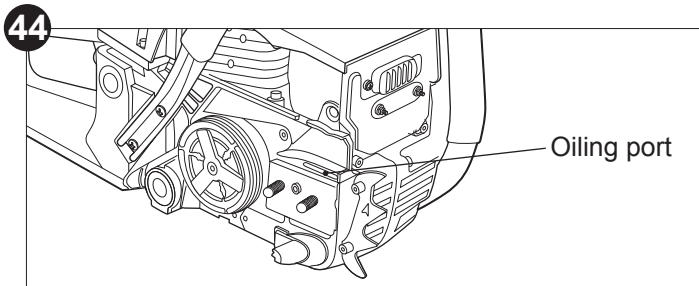

NOTE: The condition of the oil passages can be easily checked. If the passages are clear, the chain will automatically give off a spray of oil within seconds of the product starting. Your product is equipped with an automatic oiling system.

3. Check the drive sprocket. If it is worn or damaged due to strain, have it replaced by an authorised service agent.

- Remove any dirt accumulated inside the guide bar slot using the putty knife (not provided) (Fig. 45).

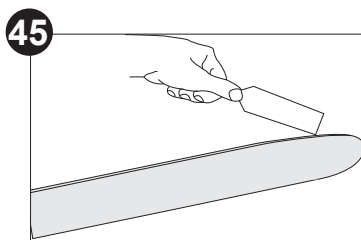

- Check the guide bar "rail" for wear: Hold a ruler (straight edge) against the side of the guide bar and "cutter side plates". If there is a gap between the ruler and guide bar the guide bar "rail" is normal. If there is no gap (ruler flush against the side of the guide bar) the guide bar "rail" is worn and needs to be replaced with a new one of the same type (Fig. 46).

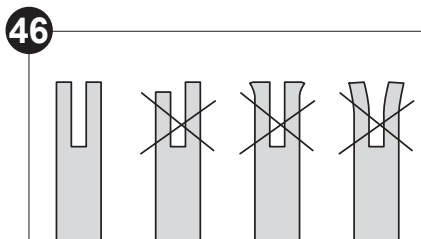

- Turn the guide bar 180° to allow even wear, thereby extending the life span of the guide bar.
- Check the saw chain for possible wear and damages. Replace it with a new one if required. Experienced user can sharpen a dull saw chain (see section "**Saw chain sharpening**" below).
- Refit the saw chain and the guide bar as described under section "**Assembly**".

Saw chain sharpening



NOTE: Never saw with a blunt chain. The saw chain is blunt if you have to push the product into the tree and the chips are very small.

- Have the saw chain (3) sharpened professionally at an authorised service centre or sharpen the chain yourself by using a proper sharpening kit. Also observe the sharpening instructions supplied with the sharpening kit.



WARNING! Only sharpen the saw chain yourself if you are trained and have experience! Use proper tools to sharpen the saw chain!

2. The height difference between the tooth and the ridge is the cutting depth. When sharpening the saw chain (3) you have to consider the following points (Fig. 47).

- > File angle
- > Cutting angle
- > File position
- > Diameter of round file
- > File depth

3. To sharpen the chain proceed as follows:

- > Use protective gloves.
- > Ensure the chain is correctly tensioned.
- > Engage the chain brake to lock the chain on the bar.

4. Use the chain file (not delivered), with diameter 1.1 times the cutting tooth depth. Make sure 20 % of the file diameter is above the cutter's top plate.

5. File at an angle perpendicular to the bar, and at an angle of 25° to the direction of travel (Fig. 48).

6. File each tooth from the inside towards outside only. File one side of the chain first than turn the saw around and repeat the process.

7. Sharpen each tooth equally by using the same number of strokes.

8. Keep all cutter lengths equal. Check the safety depth gauge height every 5 sharpenings. If the depth gauges are also trimmed it is essential that the original profile be restored.

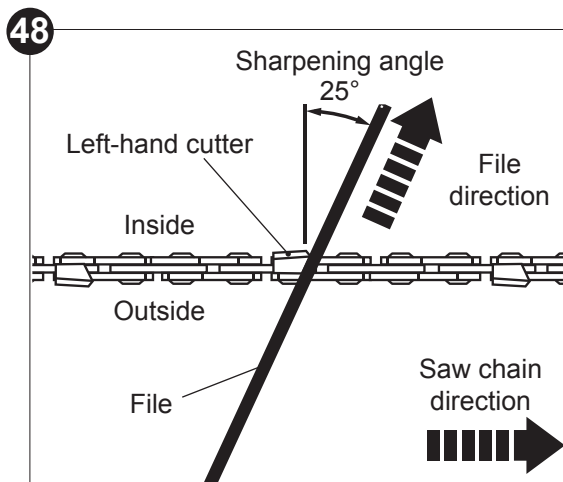
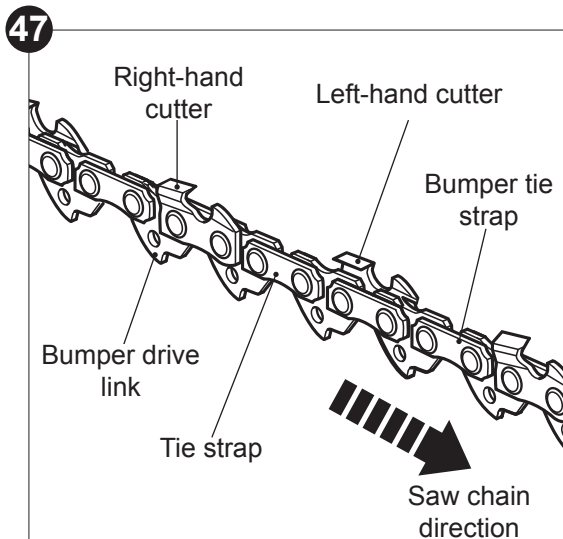

9. Use a depth gauge measuring instrument to check the height of the depth gauge. Depth gauge measuring jigs are available from most reputable tool merchants (Fig. 49).

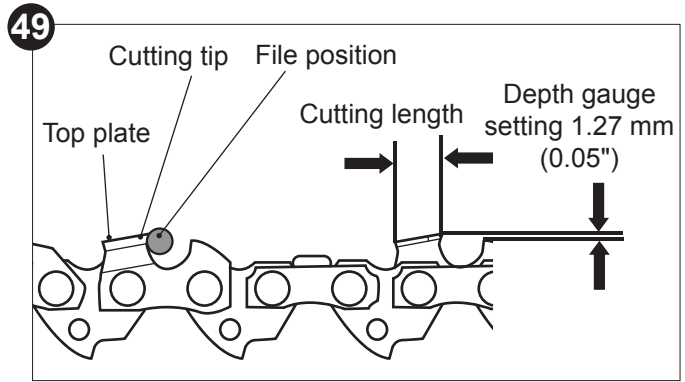

Air filter

Inspect the air filter (6b) regularly. Clean or replace it with a new one if necessary.

1. Pull the locking lever on the back cover and remove the back cover (6) (Fig. 50).
2. Loosen the fixing screw and remove the air filter (6b) (Fig. 50).
3. Split the air filter into its two parts and tap it on a stable surface to remove dust. Use compressed air (max. 3 bar) to remove stubborn dust.
4. Reassemble the two parts and refit the air filter. Refit the back cover and secure it with the locking lever.

i **NOTE:** Ensure the rubber seal between the carburettor and the air filter is clean and tightly fits in place.

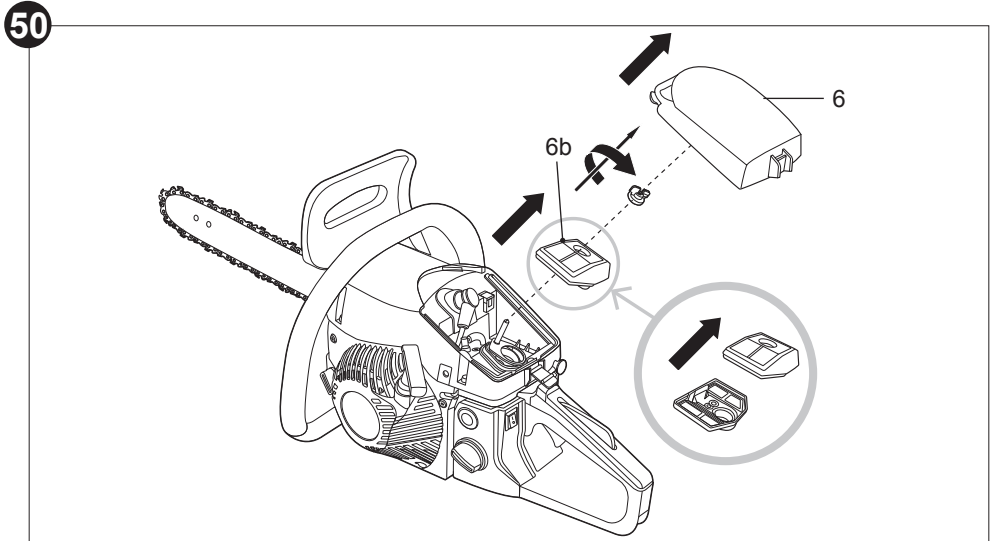

Fuel filter

The fuel tank of this product is fitted with a filter located at the free end of the fuel pipe. If it be necessary to clean or replace the fuel filter, contact an authorised service centre or a similarly qualified person.

Spark plug



NOTE: For good performance, the spark plug (17c) must be properly gapped and free of deposits.

Inspect the spark plug (6d) every 25 hours or before long-term storage over 180 days. Clean or replace with a new one if necessary (type: L8RTF(NHSP)).

1. Pull the locking lever on the back cover and remove the back cover (6).
2. Disconnect the spark plug connector (6c) (Fig. 51).
3. Loosen the spark plug anti-clockwise using the multi-tool (24) and remove it carefully.

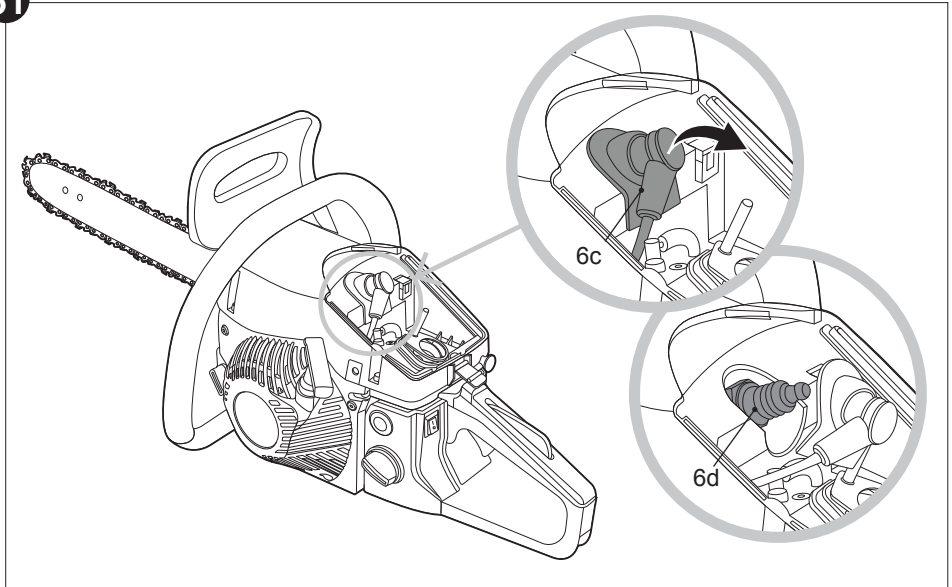
51

4. Check the spark plug for damage and wear. The colour of the electrode should be light-brown.
5. Remove the deposits from the electrode with a soft wired brush. Avoid heavy cleaning of the electrode.
6. Dry the spark plug with a soft cloth, if it is wet from fuel.
7. Check the spark plug gap. It should be 0.7 mm (Fig. 52).
8. Replace with a new spark plug if either the electrode or the insulation is damaged.
9. When replacing the spark plug, first screw it in hand tight and then lightly tighten it with the multi-tool.

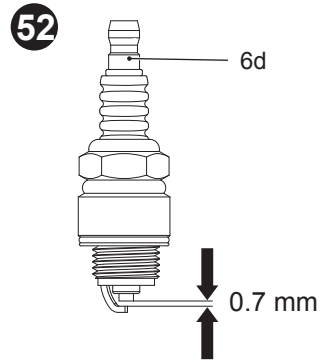

NOTE: Do not over tighten the spark plug to avoid any damage!

10. Refit the spark plug connector (6c) and back cover (6) and secure it with the locking lever.

Adjusting the carburetor



NOTES:

- > The adjustment of the carburetor should only be done by an expert!
- > The air filter has to be clean.
- > The guide bar and the saw chain have to be assembled.

The carburetor is set at the factory and should only be adjusted later if it is absolutely necessary.

The carburetor has three adjusting screws (14):

- T for adjusting the idling speed.
- L for adjusting fuel delivery at idling speed.
- H for adjusting fuel delivery at full throttle.

Use the screws L and H to adjust the quantity of fuel in relation to the air stream. Turning the screw clockwise produces a leaner fuel-air mixture (less fuel); turning the screw anti-clockwise produces a rich mixture (more fuel).

Silencer

If it be necessary to modify or replace the silencer, contact an authorised service centre or a similarly qualified person.

Spare parts/Replacement parts

The following parts of this product may be replaced by the consumer. Spare parts are available at an authorised dealer or through our customer service.

| Description | Model no. or Specification |
|---------------|--|
| Guide bar (2) | Oregon 160SDEA041 |
| Saw chain (3) | Oregon 91P057X |
| Spark plug | L8RTF (Gap of electrodes: 0.7 mm) or other model with same specifications |

Repair

This product does not contain any parts that can be repaired by the consumer. Contact an authorised service centre or a similarly qualified specialist to have it checked and repaired.

Storage



WARNING! Risk of injury! Make sure that unauthorized persons do not have access to the product!



NOTE: Good storage conditions are important for keeping your product trouble-free.

1. Clean the product as described above.
2. Attach transportation guards, if applicable.
3. Store the product and its accessories in a dry, frost-free, well-ventilated place.
4. Always store the product in a place that is inaccessible to children. The ideal storage temperature is between 10 and 30 °C.
5. Store the product in its bag or cover it with a suitable cloth to protect it against dust.

Short term storage

1. Let the product cool down before you store it.
2. Store the product as horizontally as possible. Make sure that no fuel-oil mixture can run out of the carburetor.

Long term storage



NOTE: Risk of product damage!

- > If you are not going to be using the product for a while, remove the fuel and saw chain oil from the product. This way, you will prevent a gumming-up of the engine and of the grease pump.
- > Store the product in a dry place and far away from possible sources of ignition such as ovens, gas thermostats, etc.

1. Empty both tanks if you are not going to use the product for an extended period of time (more than 3 months) and before storing it for the winter.
2. Start the engine and let it run until the engine stops by itself (see “Starting the engine”).
3. Let the engine cool down (approx. 5 min).
4. Remove the spark plug.
5. Let a teaspoon of clean two-stroke engine oil run into the combustion chamber.
6. Pull the recoil starter handle slowly several times in order to coat the internal components with the oil.
7. Refit the spark plug.

Transportation

1. Stop the engine and disconnect the spark plug connector before transporting it anywhere.
2. Attach transportation guards, if applicable.
3. Always carry the product by its handle.
4. Protect the product from any heavy impact or strong vibrations which may occur during transportation in vehicles.
5. Secure the product to prevent it from slipping or falling over, loss of fuel, damage and injury.

If you are transporting the product in a vehicle:

- > Let the product cool down.
- > Empty both tanks.
- > Secure the product against slipping.

Troubleshooting

Suspected malfunctions are often due to causes that the operators can fix themselves. Therefore check the product using this section. In most cases, the problem can be solved quickly.



WARNING! Only perform the steps described in these instructions! All further inspection, maintenance and repair work must be performed by an authorised service centre or a similarly qualified specialist if you cannot solve the problem yourself!

| Problem | Possible cause | Solution |
|--------------------------------------|--|---|
| Engine does not start | Tank empty? | Check before starting! |
| | Stop switch on O ? | Follow the engine starting procedure. |
| | Incorrect starting procedure? | Follow the engine starting procedure. |
| | Spark plug connector not firmly attached? | Attach the spark plug connector firmly. |
| | Spark plug connector is dirty? | Clean the spark plug connector. |
| | Excess fuel in the combustion chamber? | Loosen throttle trigger lock-out, press in choke knob, start engine several times. If the engine does not start: remove spark plug and dry off electrode |
| | Spark plug is soiled (tip is rusted)? | Clean spark plug |
| | Primer has been pressed at warm start? | Clean spark plug |
| | Distance from electrode to spark plug too great? | Set gap between electrodes between 0.7 mm |
| | Incorrect fuel or incorrect mixture? | Empty tank and fill up with the correct mixture |
| Filter for fuel-oil mixture clogged? | Have an expert replace it. | |

| Problem | Possible cause | Solution |
|---|--|--|
| Engine does not start. | Spark plug defective? | Replace spark plug. |
| | Engine cold? | Follow cold starting procedure. |
| | Carburetor setting not correct? | Adjust the carburetor. |
| Engine does not reach the maximum speed. | Air filter is soiled? | Clean the air filter. |
| | Spark plug is soiled (tip is rusted)? | Clean spark plug. |
| | Distance from electrode to spark plug too great? | Set gap between electrodes between 0.7 mm. |
| | Incorrect fuel or incorrect mixture? | Empty tank and fill up with the correct mixture. |
| | Carburetor setting not correct? | Adjust the carburetor. |
| Excess smoke from the engine. | Incorrect fuel or incorrect mixture? | Stop the engine and empty tank, then fill up with the correct mixture. |
| Chain does not start. | Chain brake triggered? | Loosen chain brake. |
| Chain starts up before throttle trigger is pressed. | Chain brake is not engaged? | Engage chain brake. |
| | Idling speed too high? | Press throttle trigger again slightly after starting. |
| | | Adjust the carburetor. |
| Insufficient chain lubrication/grease. | The saw chain oil tank empty? | Fill up saw chain oil. |
| | Oiling port clogged? | Clean oiling port. |
| | Wrong saw chain lubrication setting? | Increase the saw chain lubrication. |

Recycling and disposal

1. Old products are potentially recyclable and do not, therefore, belong in your household rubbish. You are requested to assist us and our contribution to saving resources and protecting the environment by handing in this product to an equipped collection centre (if there is one available).
2. Petrol, oil, used oil, a mixture of oil and petrol and objects soiled with oil e.g. cleaning cloths do not belong in the household rubbish. Dispose of oil-contaminated items in accordance with the local guidelines and hand them in at recycling centres.
3. The product comes in a package that protects it against damage during shipping. Keep the package until you are sure that all parts have been delivered and the product is operating properly. Recycle the package afterwards.

Guarantee

This product carries a guarantee of 12 months starting from the day of purchase. Please retain your receipt as a proof.

This guarantee specifically excludes losses due to:

- Normal wear and tear, including accessory wear
- Overload, misuse or neglect
- Failure of consumable items (such as batteries)
- Repairs attempted by anyone other than an authorised agent
- Accidental damage caused by foreign objects or substances
- Lack of routine maintenance
- Failure to follow manufacturer's guidelines
- Loss of use of the goods

Due to continuous product improvement, we reserve the right to change the product specification without prior notice.

This guarantee does not affect your statutory rights.

For any inquiries relating to the guarantee, contact your retailer: If you purchased this product in B&Q store or website, then call 0333 014 3357. If you bought this product in SFX outlet or website then call 03330 112 112.



(EN) EU DECLARATION OF CONFORMITY
 (FR) DÉCLARATION UE DE CONFORMITÉ
 (PL) DEKLARACJA ZGODNOŚCI UE
 (RO) DECLARAȚIA DE CONFORMITATE UE
 (ES) DECLARACIÓN UE DE CONFORMIDAD
 (PT) DECLARAÇÃO DE CONFORMIDADE UE

Product/ Produit/ Produkt/Produsul/Producto/Produto

- > Chain saw/Tronçonneuse/Pilarka łańcuchowa/Motoferastrau/Motosierra/Motosserra
- > FPCSP46-2
- > 45.8 cm³, 1.6 kW/**12000 min⁻¹**
- > 000001 - 999999

Name and address of the manufacturer or his authorised representative:

Nom et adresse du fabricant ou de son mandataire:

Nazwa i adres producenta lub jego upoważnionego przedstawiciela:

Denumirea și adresa producătorului sau a reprezentantului său autorizat:

Nombre y dirección del fabricante o de su representante autorizado:

Nome e endereço do fabricante ou do respetivo mandatário:

Kingfisher International Products B.V.,
 Rapenburgerstraat 175E,
 1011 VM Amsterdam,
 The Netherlands
www.kingfisher.com/products

This declaration of conformity is issued under the sole responsibility of the manufacturer.

La présente déclaration de conformité est établie sous la seule responsabilité du fabricant.

Niniejsza deklaracja zgodności wydana zostaje na wyłączną odpowiedzialność producenta.

Prezenta declarație de conformitate este emisă pe răspunderea exclusivă a producătorului.

La presente declaración de conformidad se expide bajo la exclusiva responsabilidad del fabricante.

A presente declaração de conformidade é emitida sob a exclusiva responsabilidade do fabricante.

Object of the declaration/Objet de la declaration/Przedmiot deklaracji/Obiectul declarației/Objeto de la declaración/Objeto da declaração

Product/Produit/Produkt/Produsul/Producto/Produto

**Model/Modèle/
Model/Modelul/
Modelo/ Modelo**

EAN

Chain saw/Tronçonneuse/Pilarka łańcuchowa/
Motoferastrau/Motosierra/Motosserra

FPCSP46-2

5059340141343

The object of the declaration described above is in conformity with the relevant Union harmonisation legislation:

L'objet de la déclaration décrit ci-dessus est conforme à la législation d'harmonisation de l'Union applicable:
Wymieniony powyżej przedmiot niniejszej deklaracji jest zgodny z odnośnymi wymaganiami unijnego prawodawstwa harmonizacyjnego:

Obiectul declarației descris mai sus este în conformitate cu legislația relevantă de armonizare a Uniunii:
El objeto de la declaración descrita anteriormente es conforme con la legislación de armonización pertinente de la Unión:

O objeto da declaração acima descrito está em conformidade com a legislação de harmonização da União aplicável:

| | |
|---|---|
| 2006/42/EC as amended | Machinery Directive |
| 2014/30/EU as amended | Directive Electromagnetic compatibility |
| 2000/14/EC as amended | Outdoor Noise Directive |
| 2016/1628/EU Regulation | Gaseous and Particulate Pollutant Emission Limits |
| 2011/65/EU as amended | Directive Restriction of the use of certain hazardous substances in electrical and electronic equipment |
| 2006/42/CE en tant que directive modifiée sur les machines | |
| 2014/30 / UE telle que modifiée | Directive Compatibilité électromagnétique |
| 2000/14/CE en tant que directive modifiée sur le bruit extérieur | |
| 2016/1628/Règlement de l'UE | Limites d'émission de gaz et de particules |
| Directive 2011/65 / UE telle que modifiée | Limitation de l'utilisation de certaines substances dangereuses dans les équipements électriques et électroniques |
| 2006/42/WE w zmienionej dyrektywie maszynowej | |
| 2014/30 / UE ze zmianami | Dyrektywa Kompatybilność elektromagnetyczna |
| 2000/14/WE w zmienionej dyrektywie w sprawie hałasu na zewnątrz | |
| 2016/1628/UE | limity emisji zanieczyszczeń gazowych i cząstek stałych |
| 2011/65 / UE ze zmianami | Dyrektywa Ograniczenie stosowania niektórych niebezpiecznych substancji w sprzęcie elektrycznym i elektronicznym |
| 2006/42/CE, astfel a fost modificată | Directiva privind echipamentele |
| 2014/30/UE, astfel a fost modificată | Directiva privind compatibilitatea electromagnetică |
| 2000/14/CE, astfel a fost modificată | Directiva privind zgomotul în aer liber |
| 2016/1628/UE | Regulamentul privind emisiile de poluanți gazoși și de particule poluante |
| 2011/65/UE, astfel a fost modificată | Directiva privind limitarea utilizării anumitor substanțe periculoase în echipamentele electrice și electronice |
| Directiva sobre maquinaria modificada | 2006/42/CE |
| 2014/30/UE modificada | Directiva Compatibilidad electromagnética |
| 2000/14/CE modificada | Directiva sobre ruido al aire libre |
| 2016/1628/Reglamento de la UE | Límites de emisiones de contaminantes gaseosos y partículas |
| 2011/65/UE modificada | Directiva Restricción del uso de determinadas sustancias peligrosas en equipos eléctricos y electrónicos |
| 2006/42/CE como diretiva de máquinas alteradas | |
| 2014/30/UE como alteração da compatibilidade eletromagnética | |
| 2000/14/CE como diretiva de ruído exterior alterada | |
| Limites de emissão de poluentes gasosos e de poluentes de partículas | 2016/1628/REGULAMENTO da UE |
| 2011/65/UE como restrição diretiva alterada da utilização de certas substâncias perigosas em equipamentos elétricos e eletrônicos | |

Measured Sound Power Level/ Le niveau de puissance acoustique mesuré/ Zmierzony poziom mocy akustycznej/ Nivel de putere acustică măsurat/ Nivel de potencia sonora medido / Nivel de potência sonora medido: 106.6 dB(A)

Guaranteed Sound Power Level/ Le niveau de puissance acoustique garant/ Gwarantowany poziom mocy akustycznej/ Nivel de putere acustică garantat/ Nivel de potencia sonora garantizado/ Nivel de potência sonora garantido: 110 dB (A)

Engine Model/ Modèle de moteur/ Model silnika/ Modelul motorului/ Modelo de motor/ Modelo de motor: 1E43F-2

References to the relevant harmonised standards used or references to the other technical specifications in relation to which conformity is declared:

Références des normes harmonisées pertinentes appliquées, y compris la date de celles-ci, ou des autres spécifications techniques, y compris la date de celles-ci, par rapport auxquelles la conformité est déclarée: Odwołania do odnośnych norm zharmonizowanych, które zastosowano, wraz z datą normy, lub do innych specyfikacji technicznych, wraz z datą specyfikacji, w odniesieniu do których deklarowana jest zgodność: Trimiteri la standardele armonizate relevante folosite, inclusiv data standardului, sau trimiteri la celelalte specificații tehnice, inclusiv data specificațiilor, în legătură cu care se declară conformitatea:

Referencias a las normas armonizadas pertinentes utilizadas, incluidas las fechas de las normas, o referencias a las otras especificaciones técnicas, incluidas las fechas de las especificaciones, respecto a las cuales se declara la conformidad:

Referências às normas harmonizadas aplicáveis utilizadas, incluindo a data da norma, ou às outras especificações técnicas, incluindo a data da especificação, em relação às quais é declarada a conformidade:

EN ISO 11681-1:2011
EN ISO 14982:2009

Where applicable, the notified body TUV SUD Product Service GmbH, No.0123 performed EC Type Examination and issued the certificate: No.M6A 106544 0013 Rev.00

Le cas échéant, l'organisme notifié TUV SUD Product Service GmbH, No.0123 a effectué EC Type Examination et a établi le certificate : No.M6A 106544 0013 Rev.00

W stosownych przypadkach jednostka notyfikowana TUV SUD Product Service GmbH, No.0123 przeprowadziła EC Type Examination i wydała certyfikat: No.M6A 106544 0013 Rev.00

După caz, organismul notificat TUV SUD Product Service GmbH, No.0123 a efectuat EC Type Examination și a emis certificatul: No.M6A 106544 0013 Rev.00

Si procede, el organismo notificado TUV SUD Product Service GmbH, No.0123 ha efectuado EC Type Examination y expide el certificado: No.M6A 106544 0013 Rev.00

Se for esse o caso, o organismo notificado TUV SUD Product Service GmbH, No.0123 efetuou EC Type Examination e emitiu o certificado: No.M6A 106544 0013 Rev.00

Authorized signatory and technical file holder/Signataire et responsable de la documentation technique autorisé/Podmiot uprawniony do wystawienia i adres przechowywania dokumentacji technicznej/ Semnatar autorizat și deținătorul dosarului tehnic/Firmante autorizado y titular del expediente técnico/Signatário autorizado e detentor da ficha técnica:

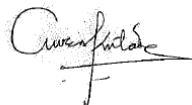

David Awe
Group Quality & Sustainability Director
On/le/dnia/la/am/el/em: 11/08/2020

Kingfisher International Products B.V.,
Rapenburgerstraat 175E,
1011 VM Amsterdam, The Netherlands
www.kingfisher.com/products



**Manufacturer, Fabricant, Prodecnt,
Producător, Fabricante:**

UK Manufacturer:

Kingfisher International Products Limited
3 Sheldon Square London W2 6PX
United Kingdom

EU Manufacturer:

Kingfisher International Products B.V.
Rapenburgerstraat 175E 1011 VM Amsterdam
The Netherlands



www.diy.com
www.screwfix.com
www.screwfix.ie

To view instruction manuals online,
visit www.kingfisher.com/products